

# DEDERIK

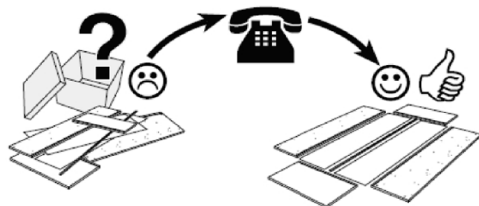

KÓD	ROZMER	BALÍK-0001	BALÍK-0002
022391	1867x850x2		2
134648	1837.5x421x15	1	
134649	1900x544x15	1	
134650	1900x573x15		1
328584	1673x527x15	2	
328615	829x420x15	2	
633453	865x1888x15		2
S39666	865x5x2		2

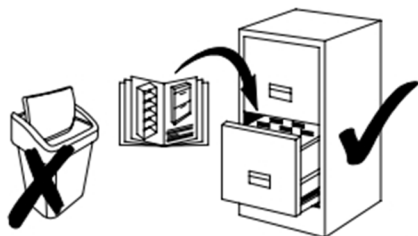

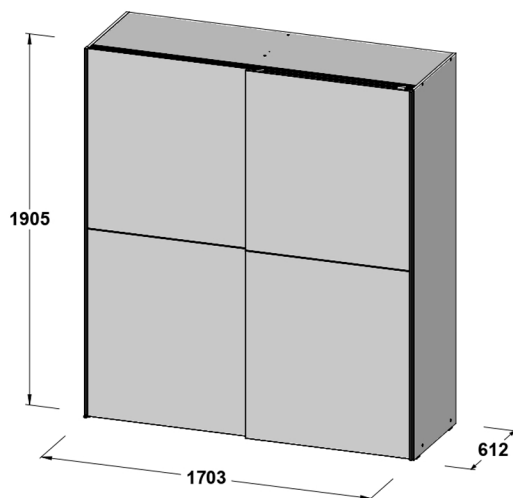
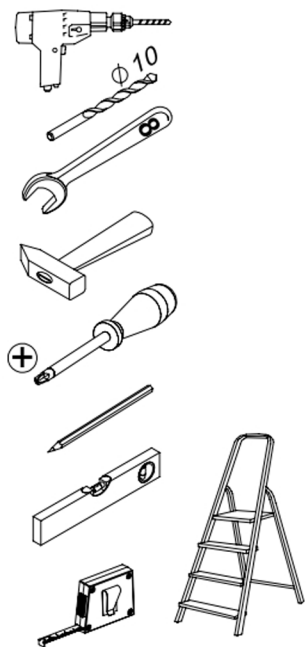
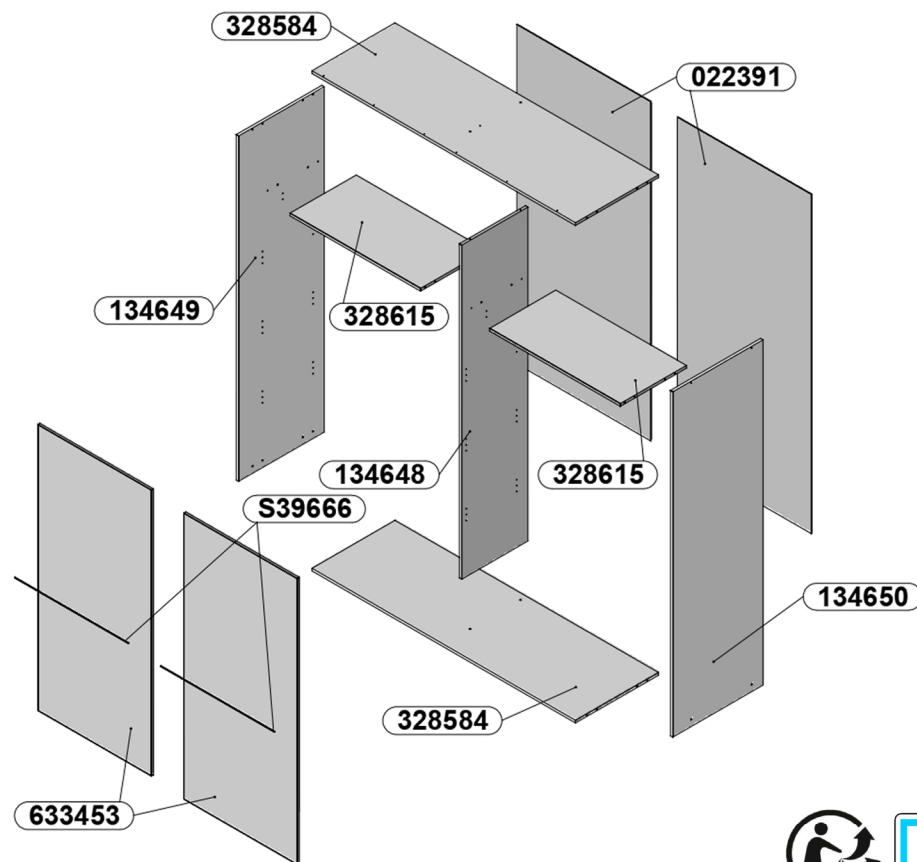
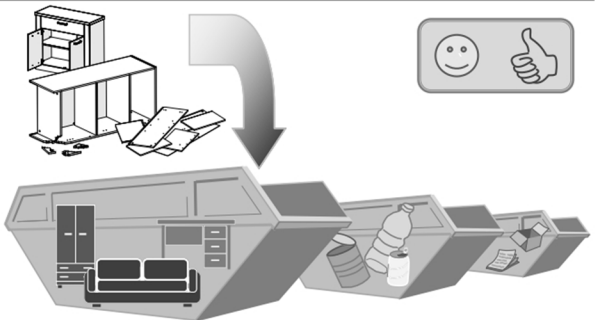
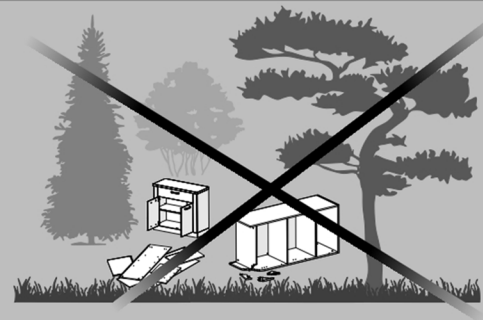
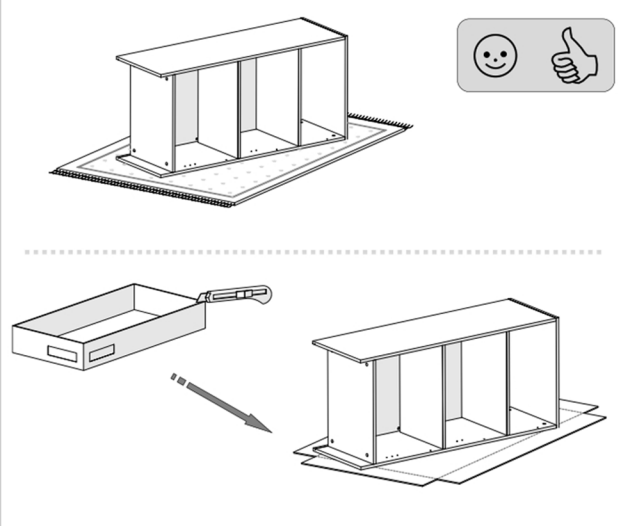
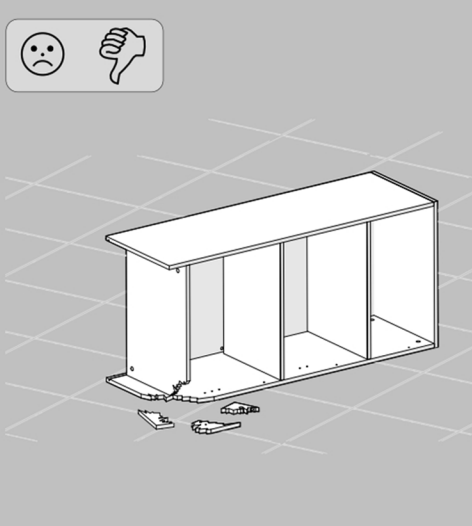
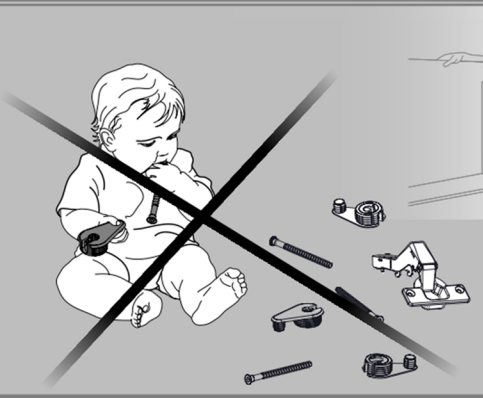
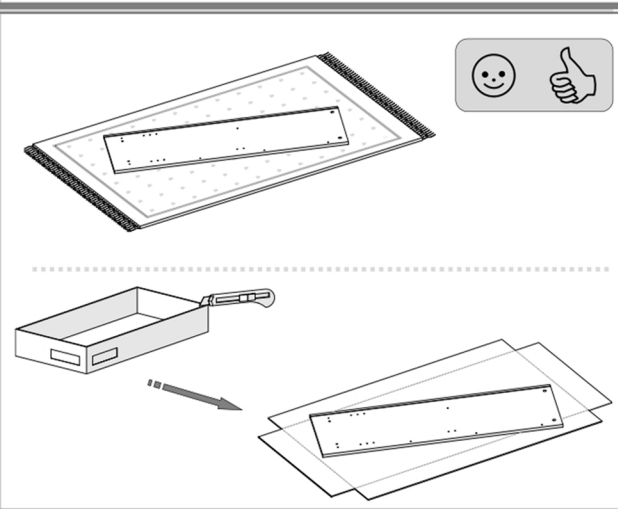
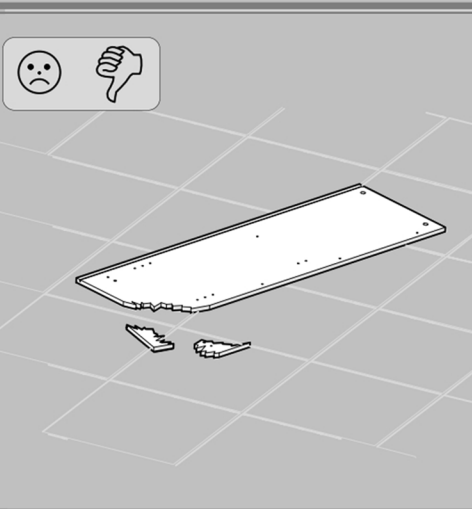
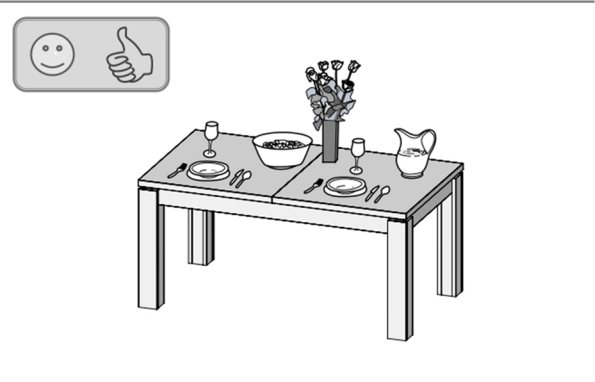
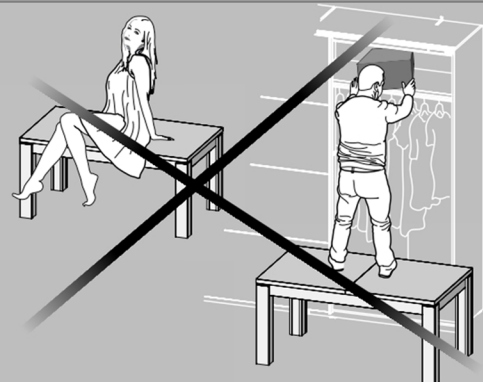
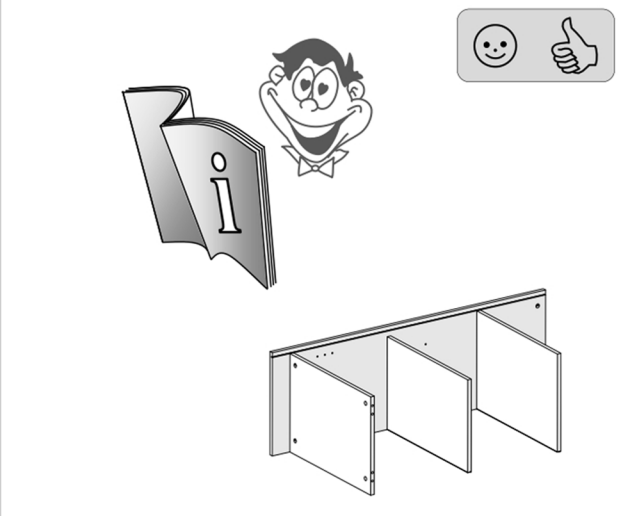
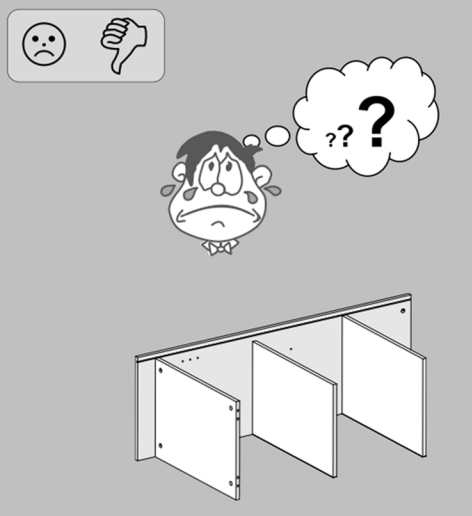
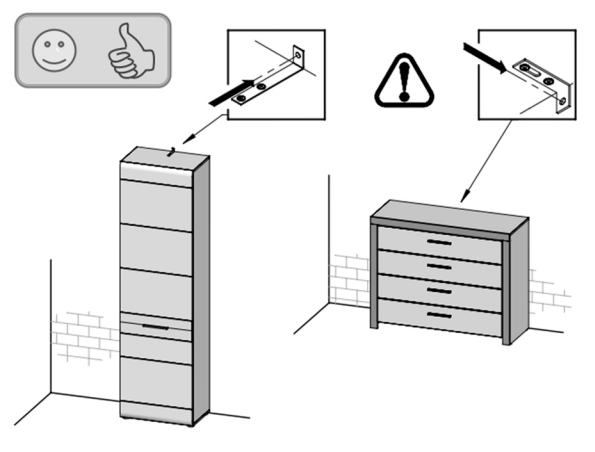
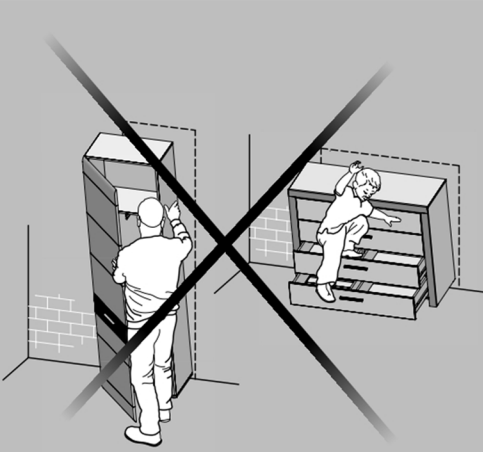

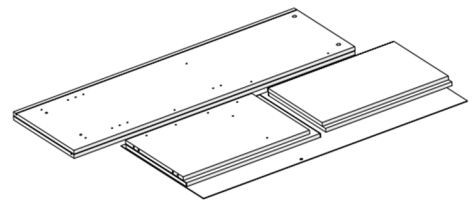
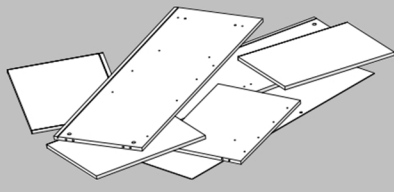

**MONTÁŽ BY MALA BYŤ VYKONANÁ V SÚLADE S NÁVODOM, KTORÝ VYPRACOVAL VÝROBCA - V OPAČNOM PRÍPADO MÔŽE DÔJSŤ K NEBEZPEČENSTVU.**

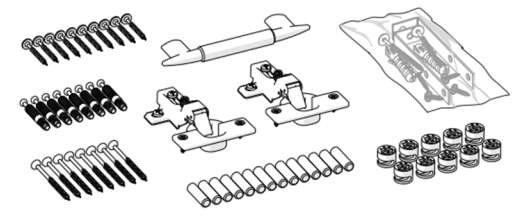
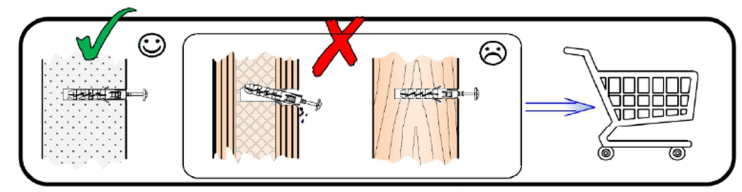

Pred zavesením nábytku alebo jeho pripevnením na stenu (za účelom zaistenia pred prevrátením) predtým skontrolujte druh a odolnosť steny. Vyberte k druhu steny vhodné hmoždinky a skrutky. V prípade pochybností kontaktujte špecialistu. Montáž musí byť vykonaná kompetentnou osobou. **POZOR!!!** Pokiaľ sú k výrobku priložené hmoždinky so skrutkami, sú určené len a výhradne do stien zhotovených z masívnych a homogénnych materiálov.

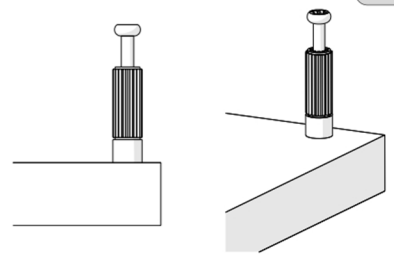
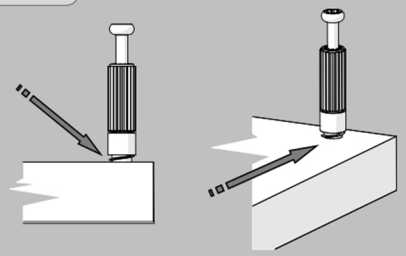



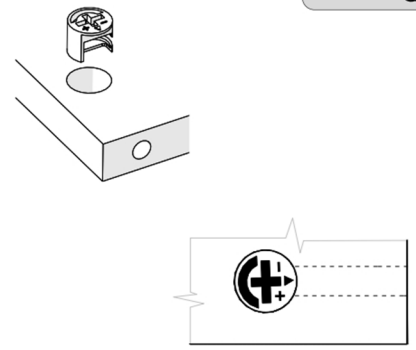
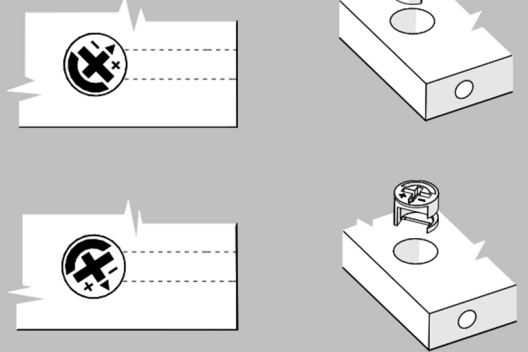



Z nábytku, ktorý má niektoré časti vyrobené z panelov na báze dreva (drevotrieskové dosky, drevovláknité dosky, preglejka atď.), sa môžu do ovzdušia v interiéri uvoľňovať zanedbateľné množstvá látok používaných vo výrobných procesoch. Úroveň týchto emisií je kontrolovaná a spĺňa platné normy. Po zložení nábytku sa odporúča pravidelne vetrať miestnosť, v ktorej ste umiestnili zmontovaný nábytok. Vetrajte približne štyri týždne alebo kým zápach nezmizne.



<b>16x S70969</b>  Ø8x28	<b>8x S30211</b> 	<b>8x S30212</b>  Ø15x12	<b>10x S30129</b>  Ø3,5x25
<b>37x S30161</b>  Ø4x16	<b>4x S34701</b>  Ø4x14	<b>5x S30157</b>  Ø4x30	<b>26x S31298-14</b>  Ø4x14
<b>12x S32080</b>  Ø6,4x50	<b>70x S31299</b>  Ø1,6x30	<b>12x S30312</b> 	<b>8x S3yyyy</b> 
<b>5x S38808</b> 	<b>4x S34702</b> 	<b>2x S32892</b> 	<b>1x S20557</b> 
	<b>4x S33396</b> 	<b>4x S38389</b> 	<b>1x S30066</b> 
<b>2x S36628</b>  Ø10x50, Ø5x60	<b>2x S34802</b>  L=822		
<b>2x S38812</b>  L - 1888			
<b>1x S37912-N</b>  L - 1672	<b>1x S37911-N</b>  L - 1672		

## S36417-N

<b>2x S36482-N</b> 	
<b>2x S36480-N</b> 	
<b>2x S36479-N</b> 	
<b>2x S36165</b> 	<b>1x S36483-N</b> 
<b>2x S36478-N</b> 	
<b>2x S36481-N</b> 	



**1** x1

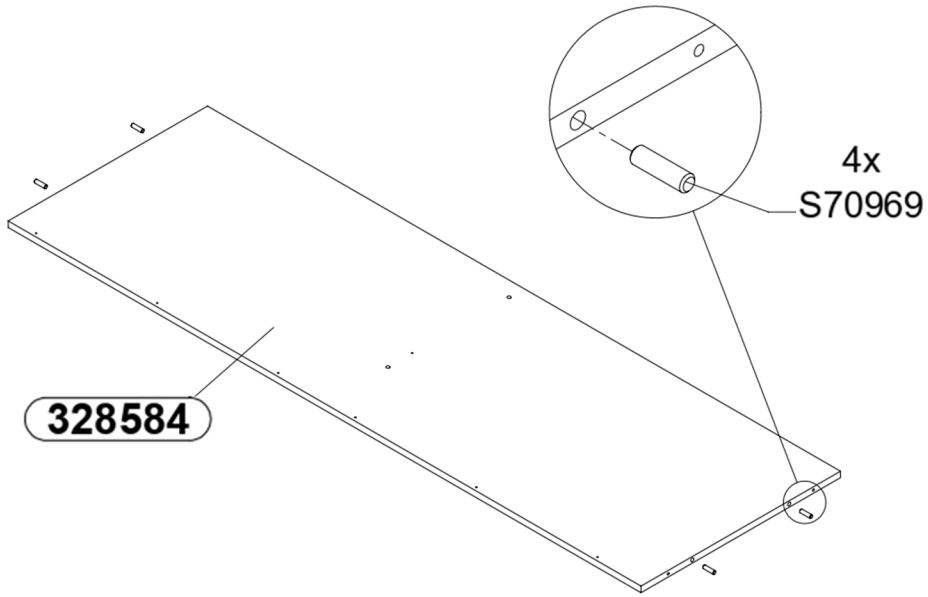

**2**

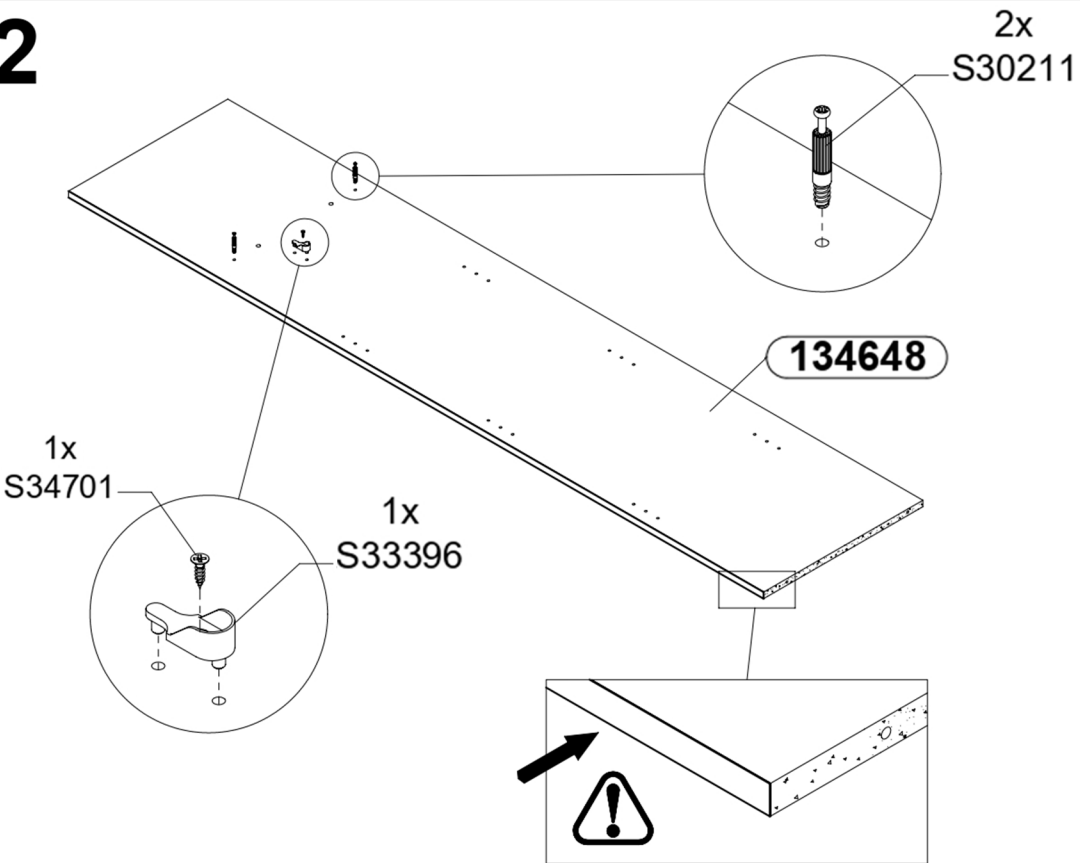

**3**

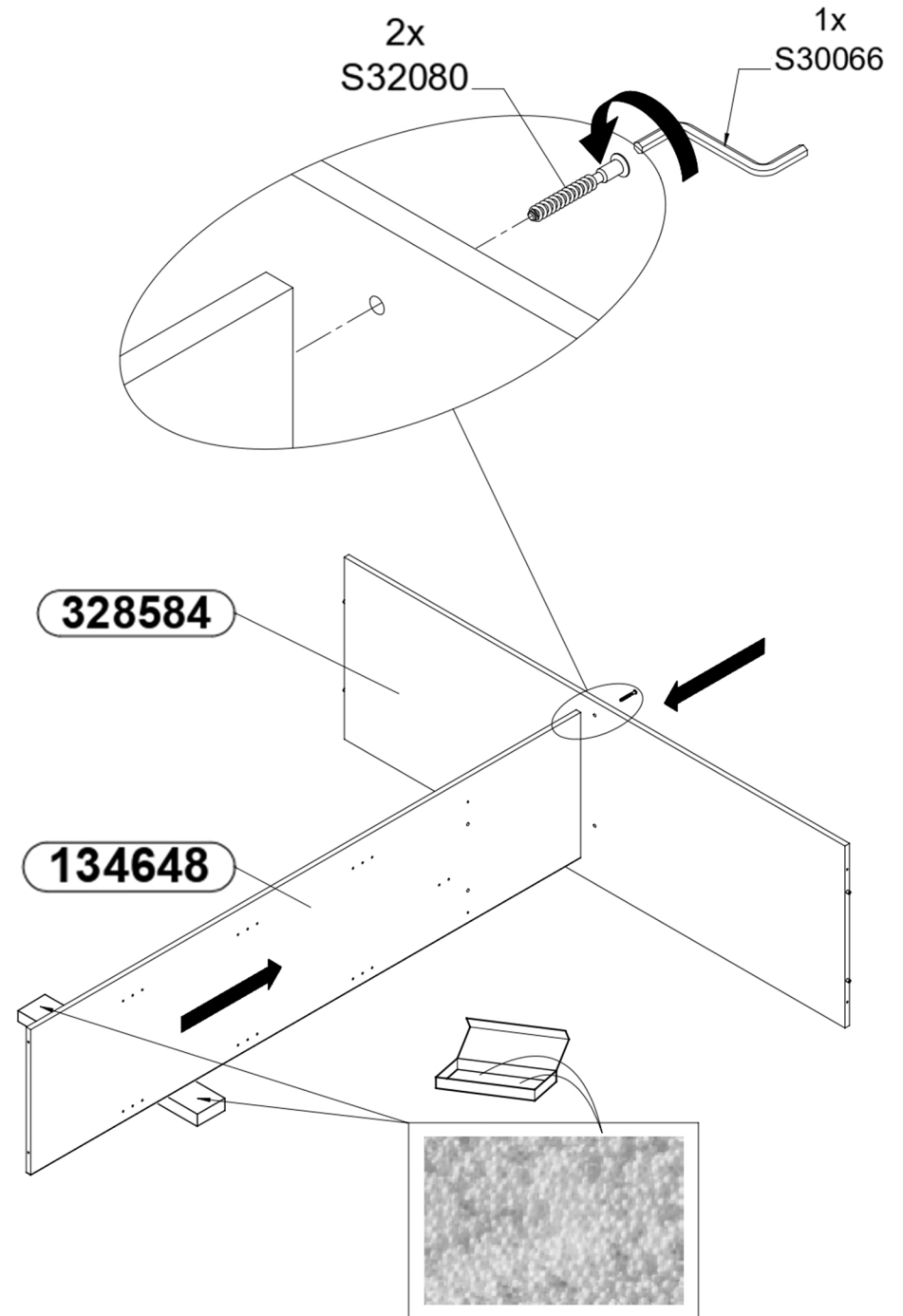

4x1

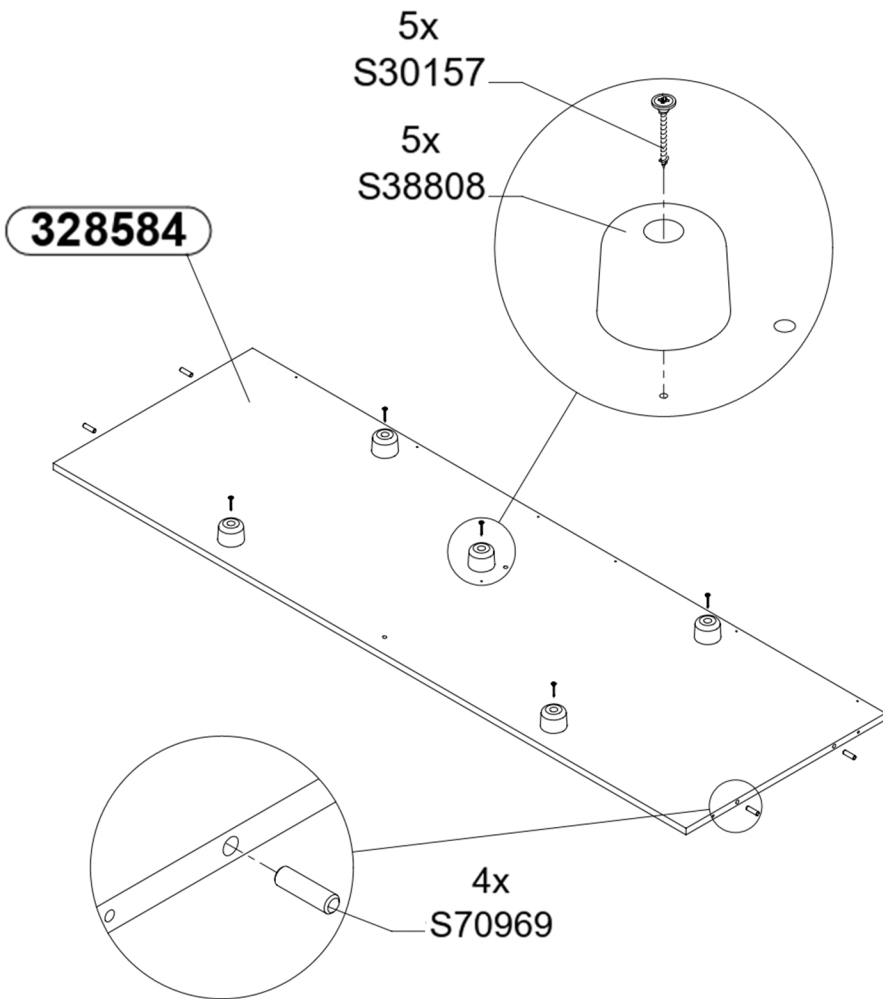
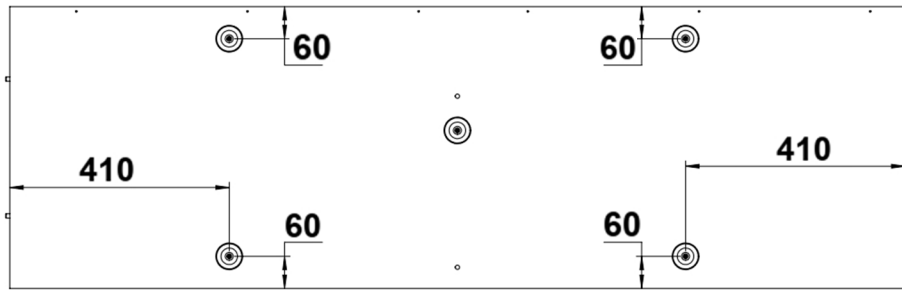

5

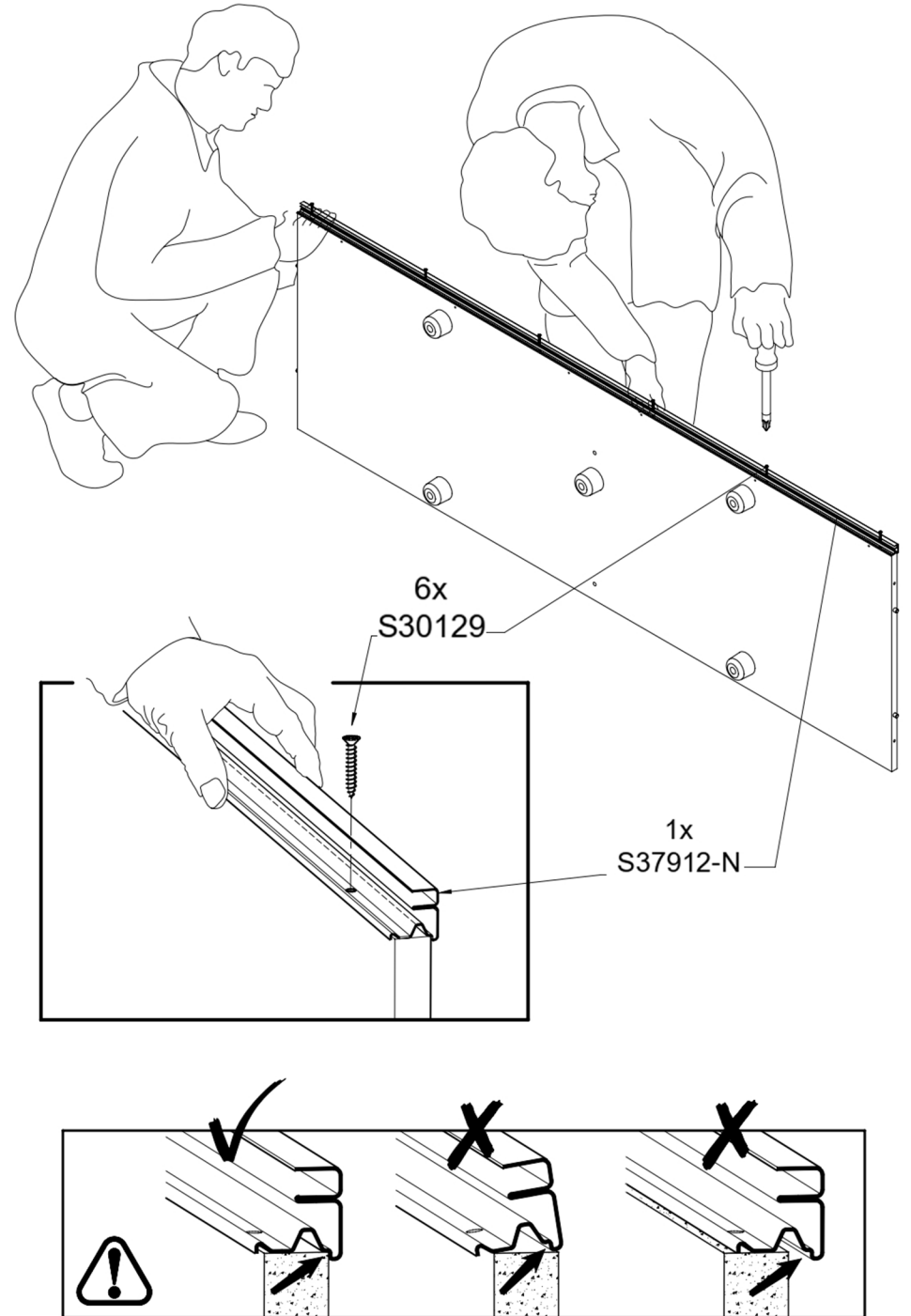

6

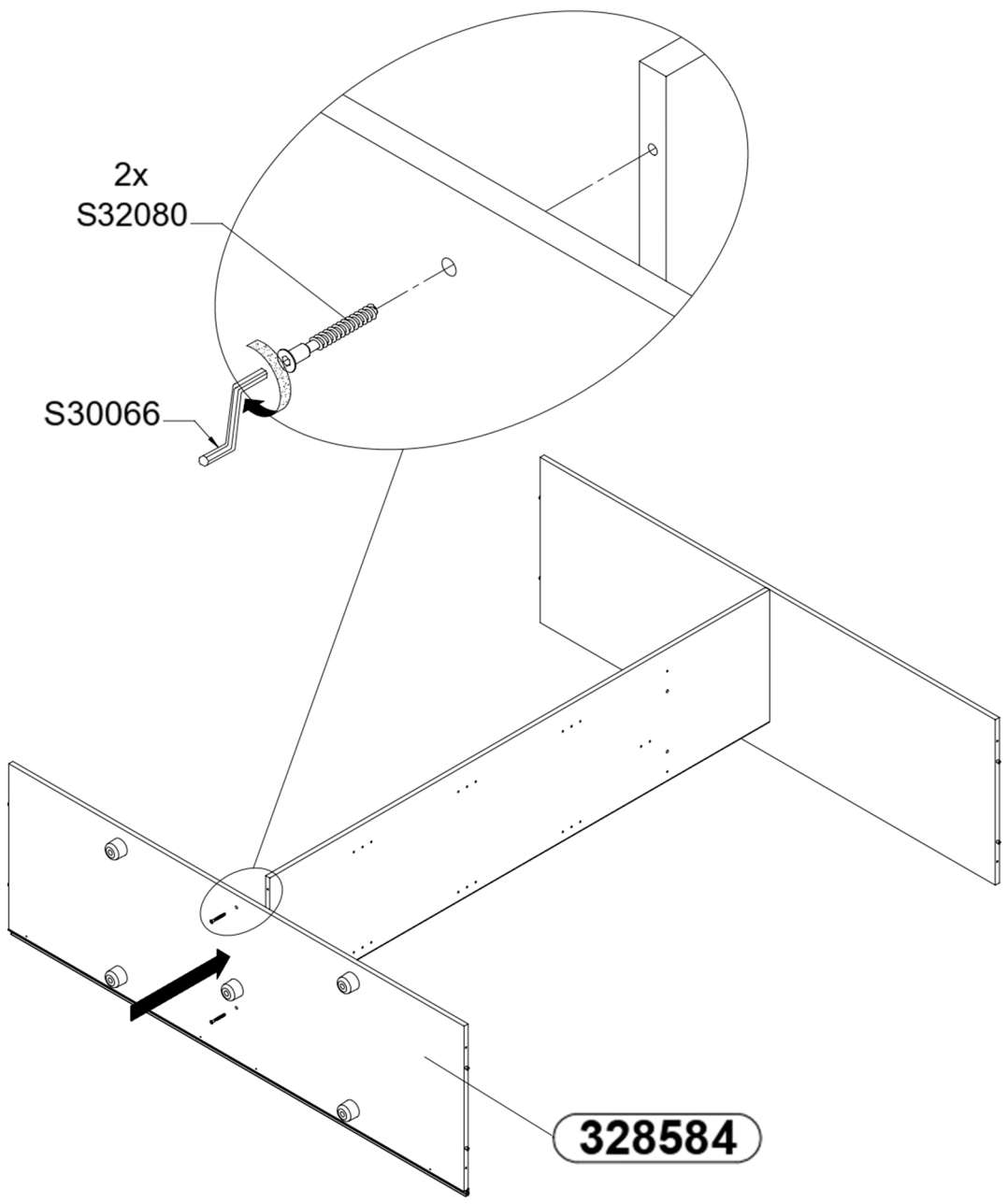

7

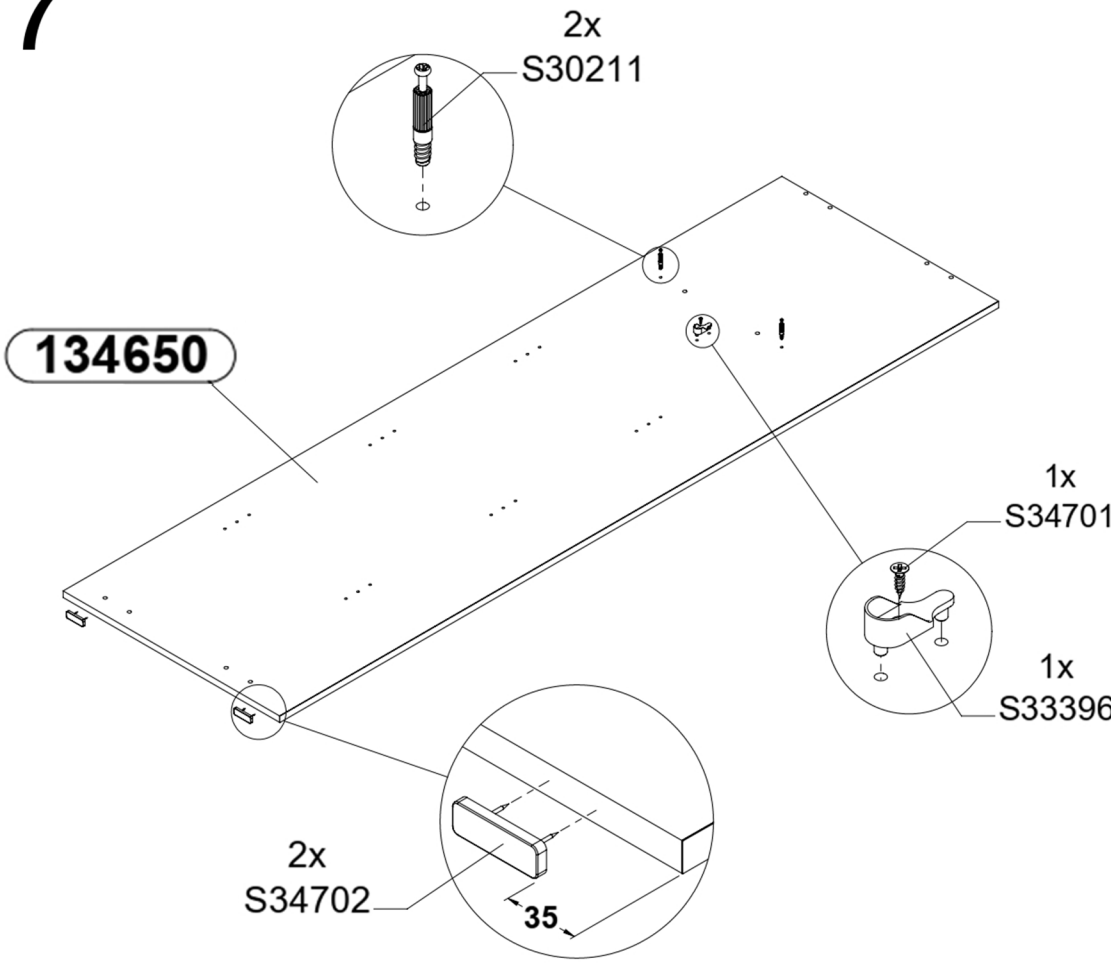

8 x2

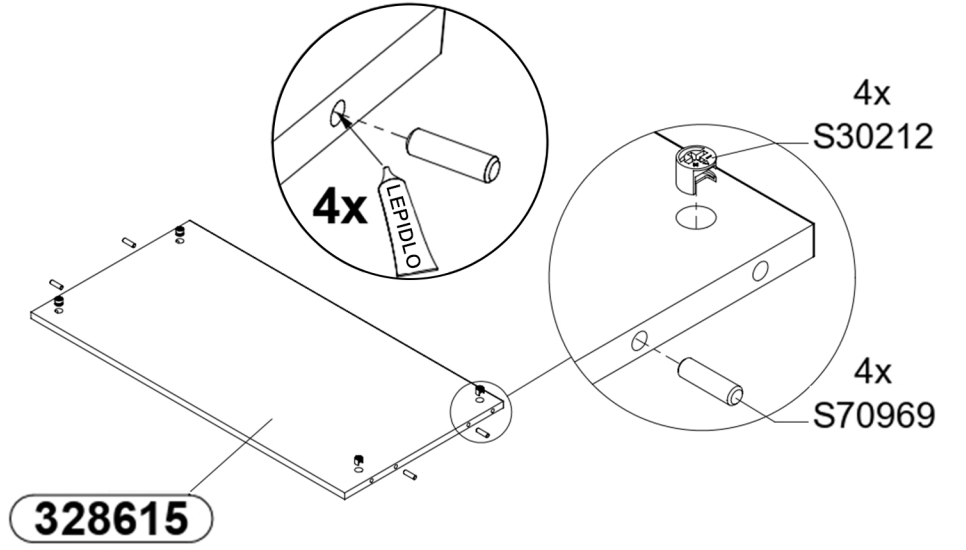

9

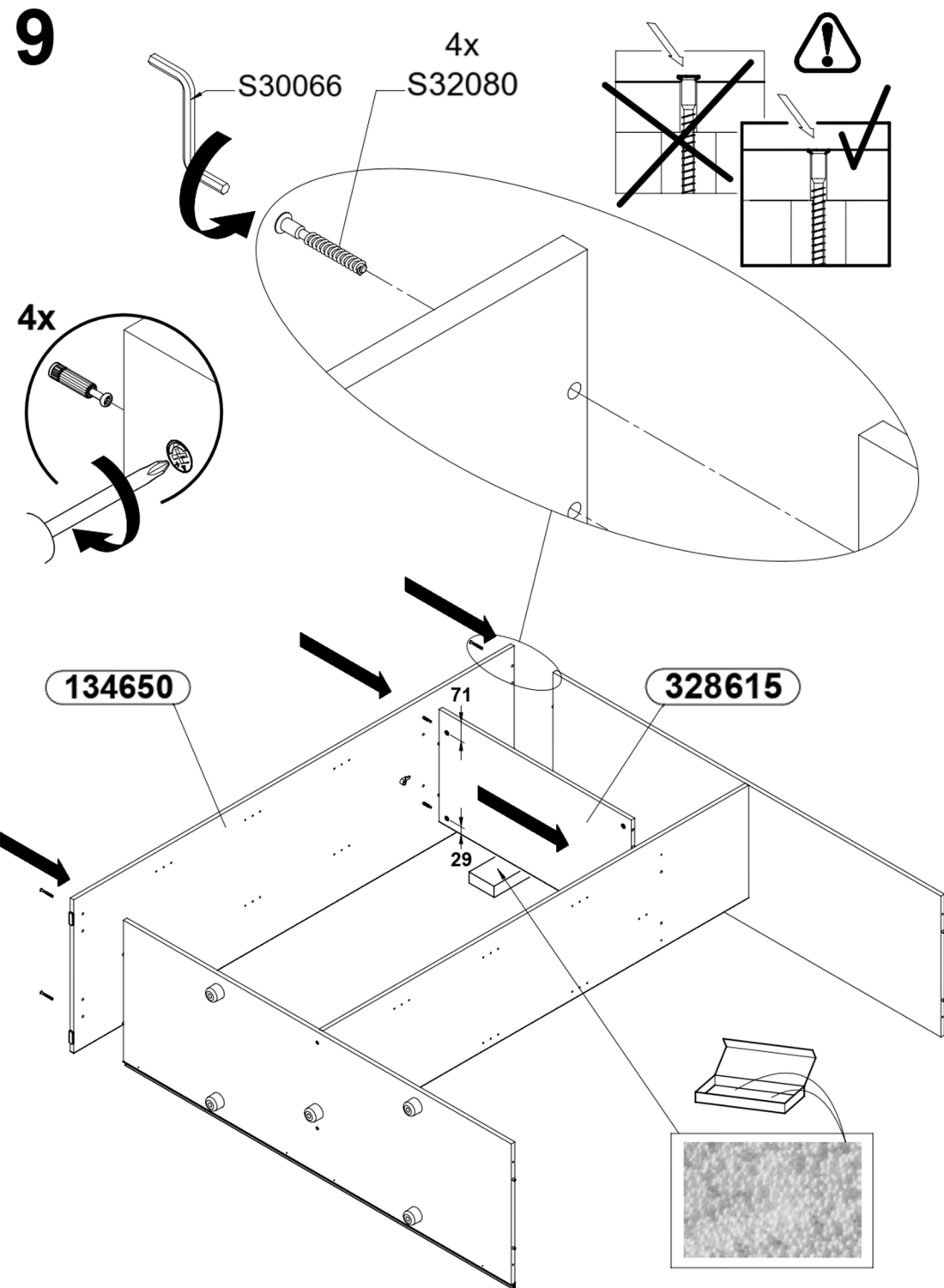

10

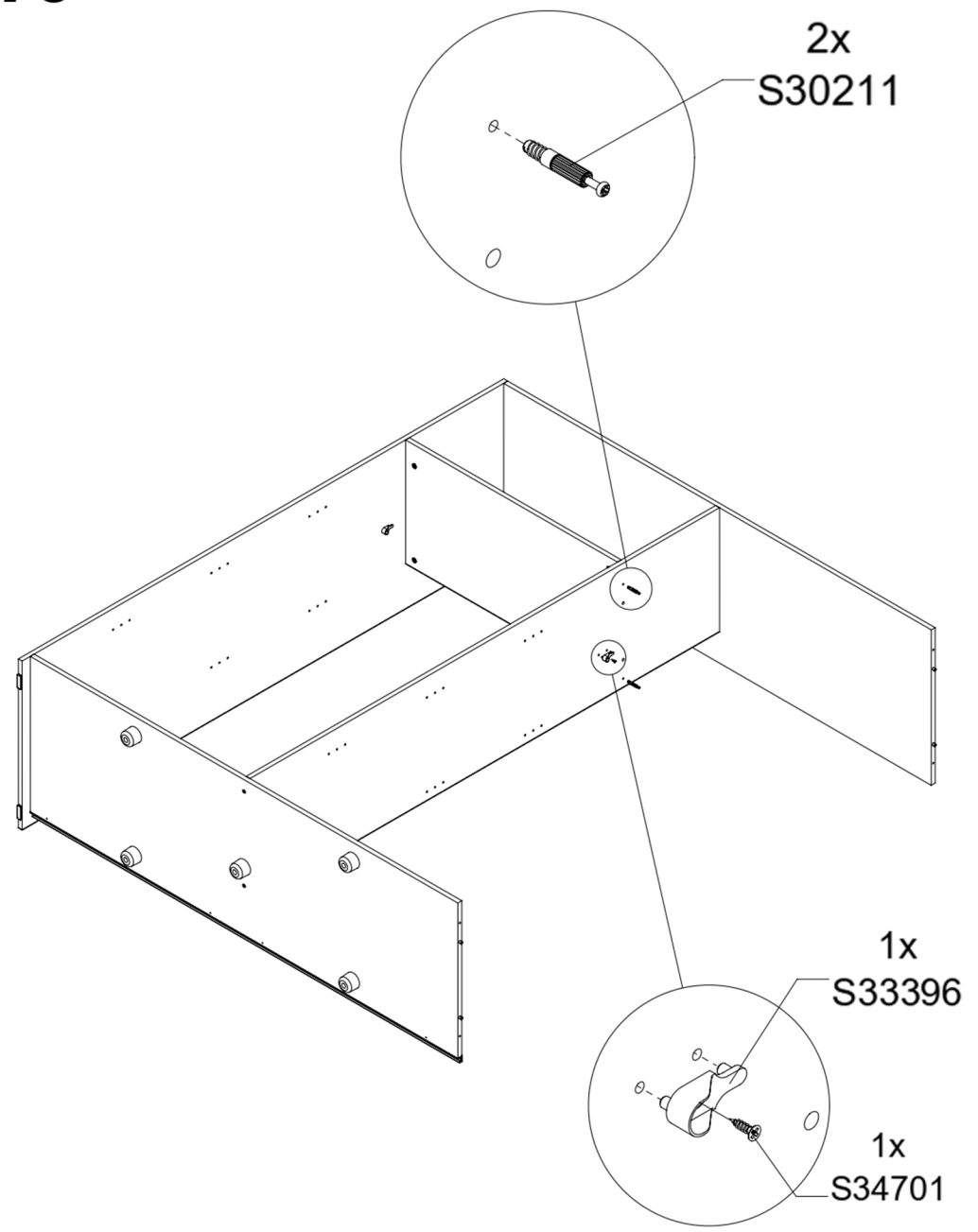



# 11

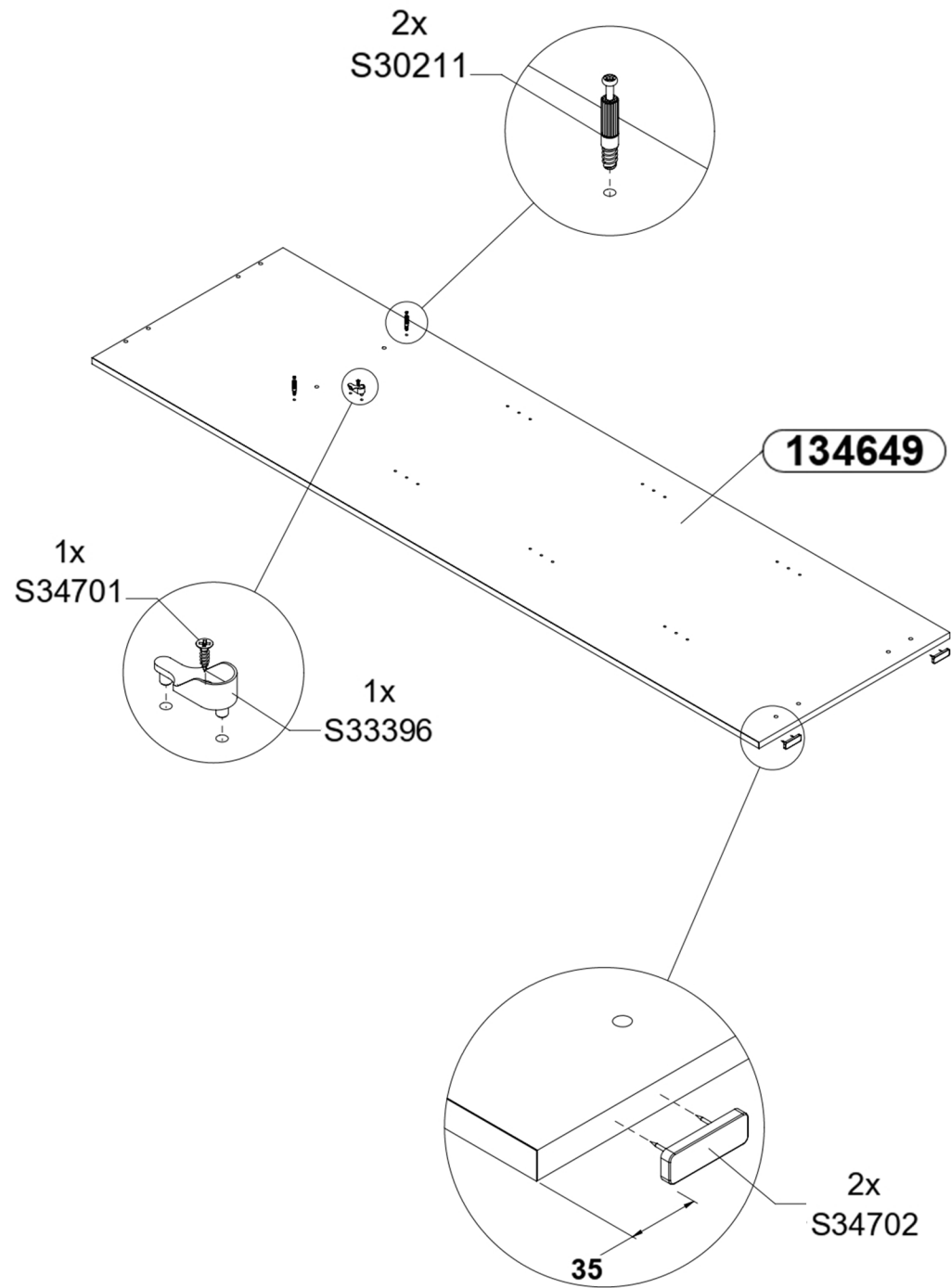

# 12

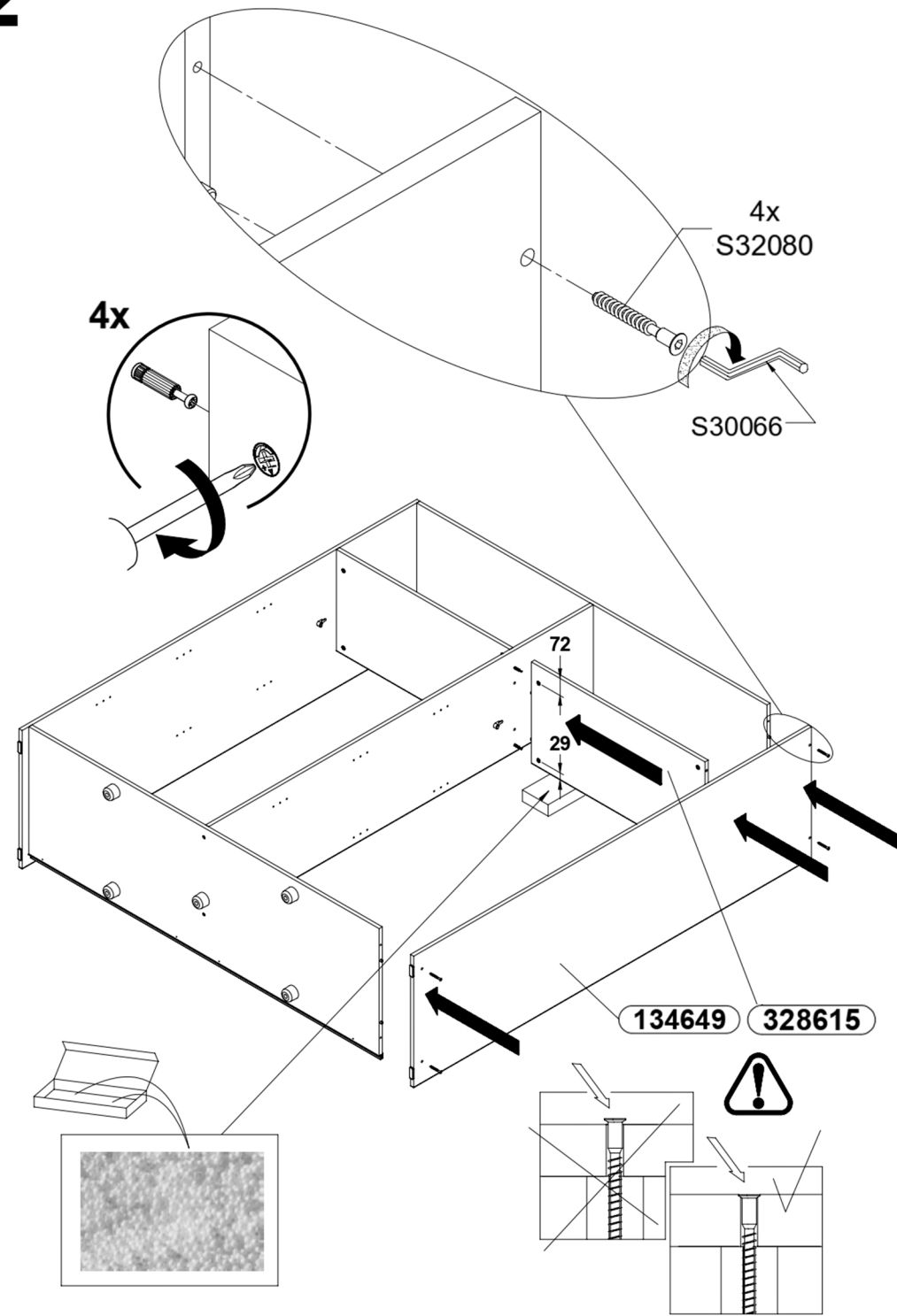

# 13

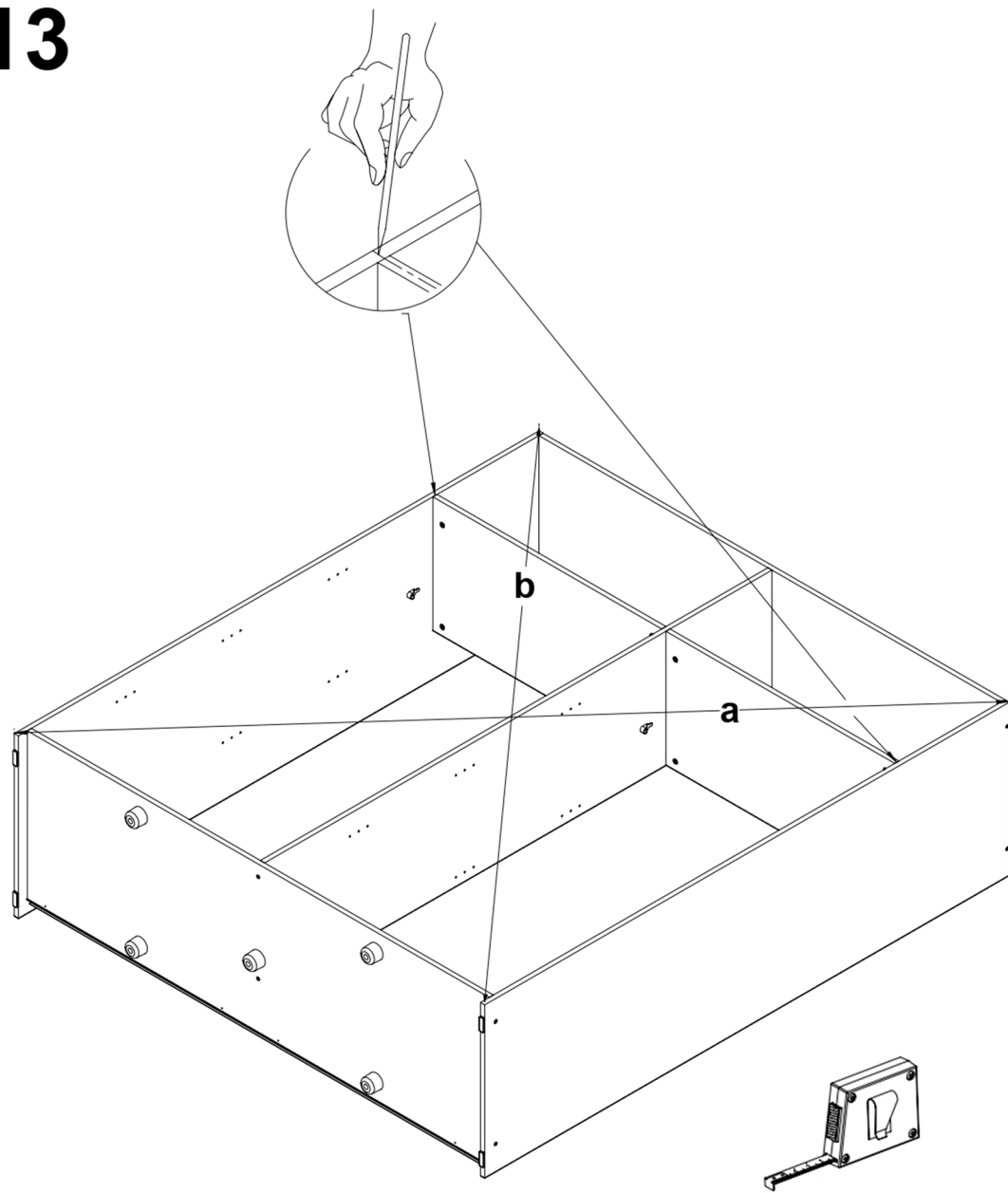

**a = b**

# 14

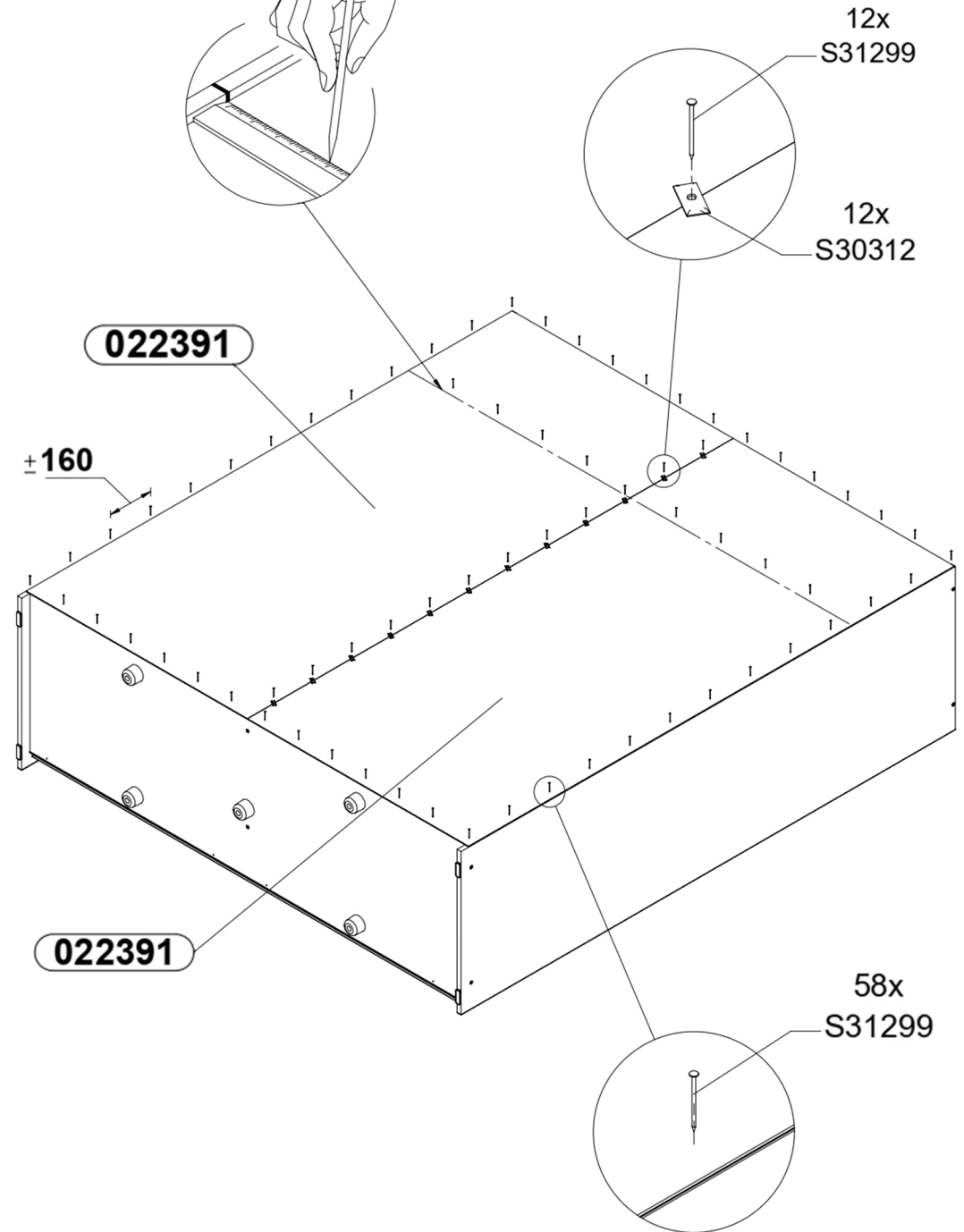



AK CHCETE ZABRÁNIŤ PREVRÁTENIU NÁBYTKU, JE POTREBNÉ HO TRVALO PRIPEVNIŤ KU STENE.

15

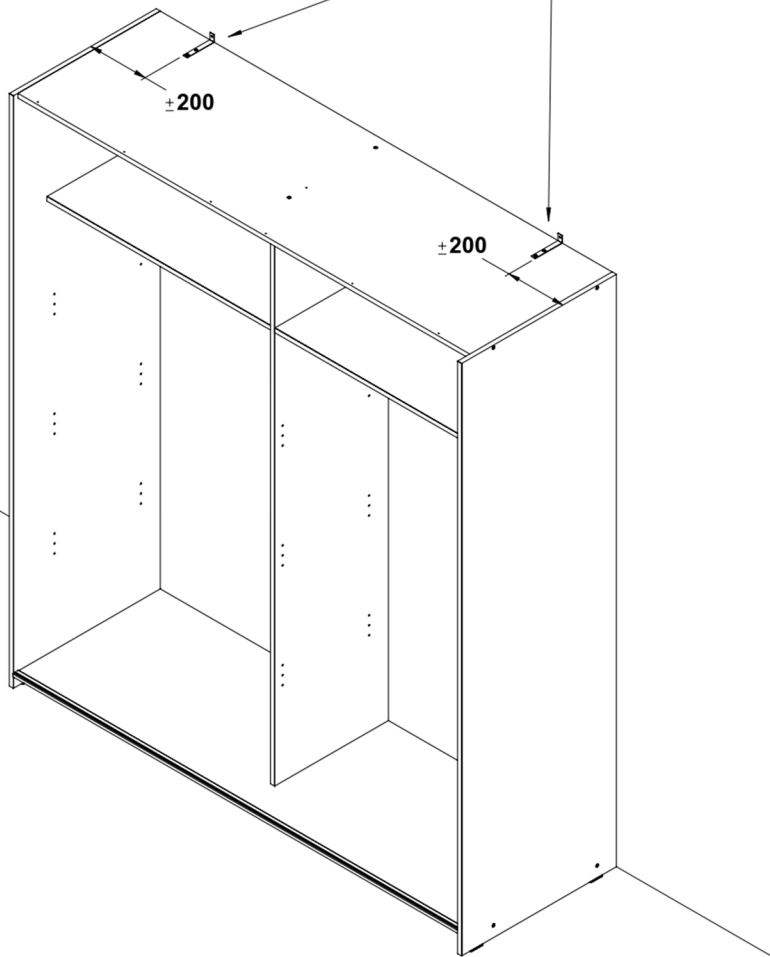
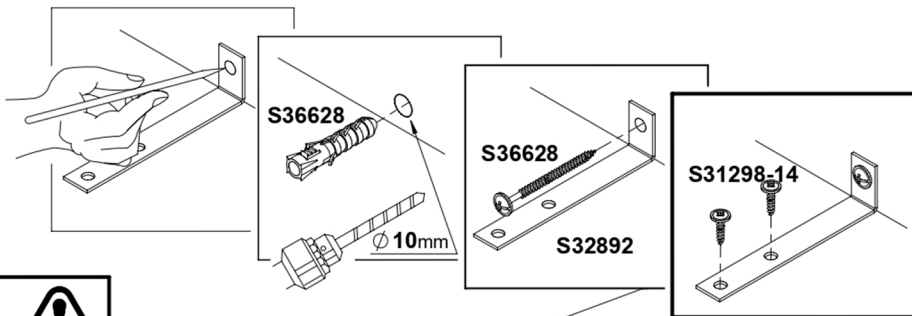

16



=

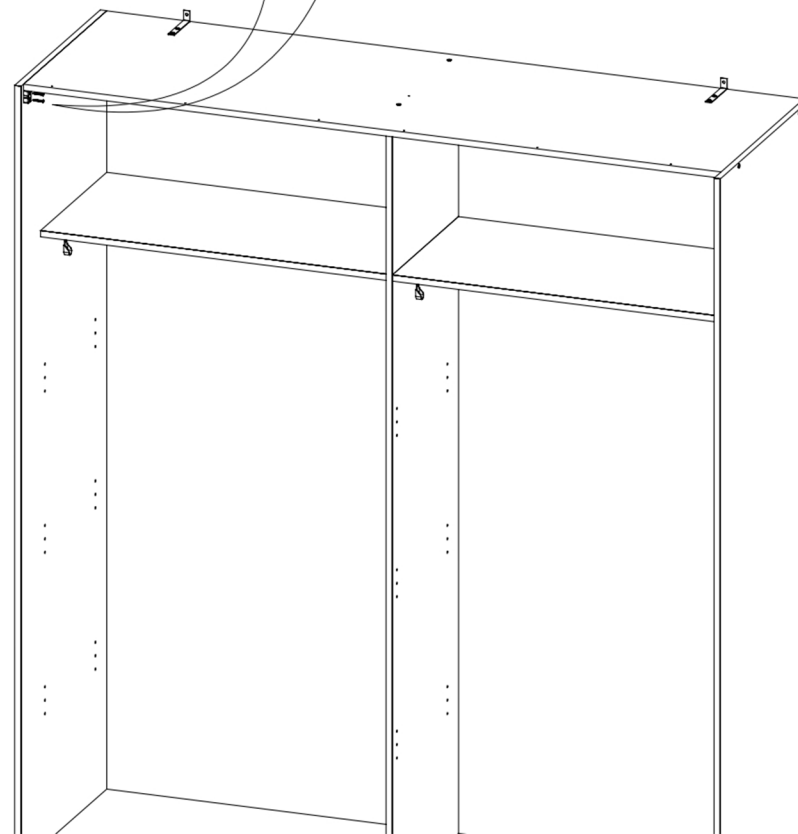
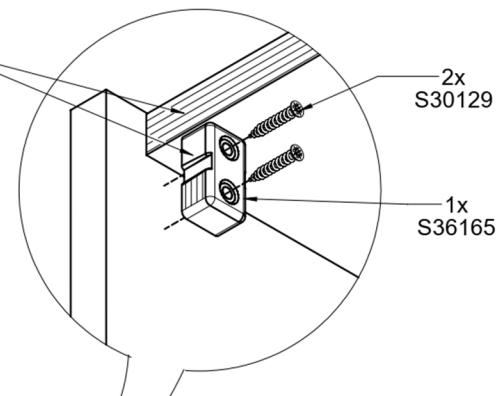
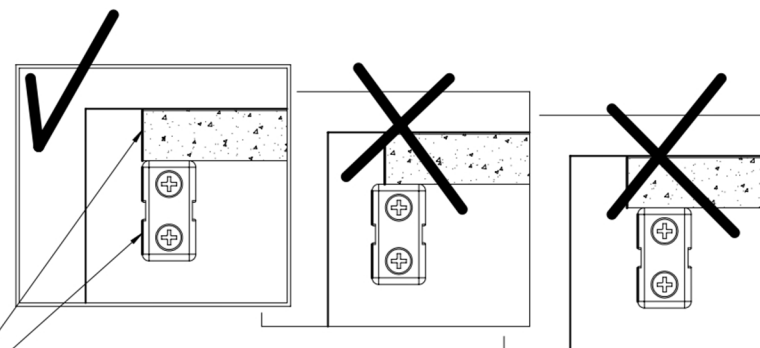

# 17

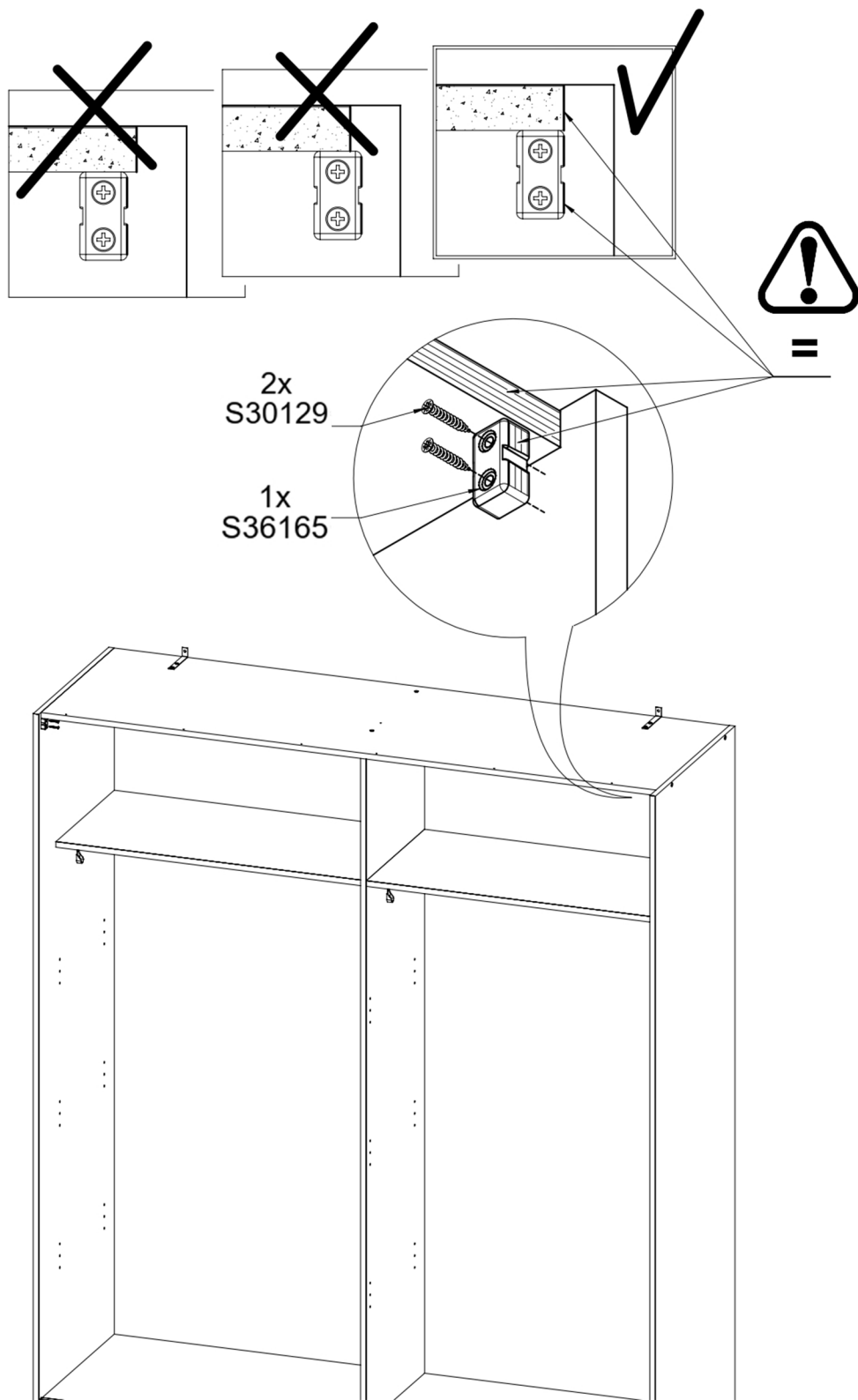

# 18

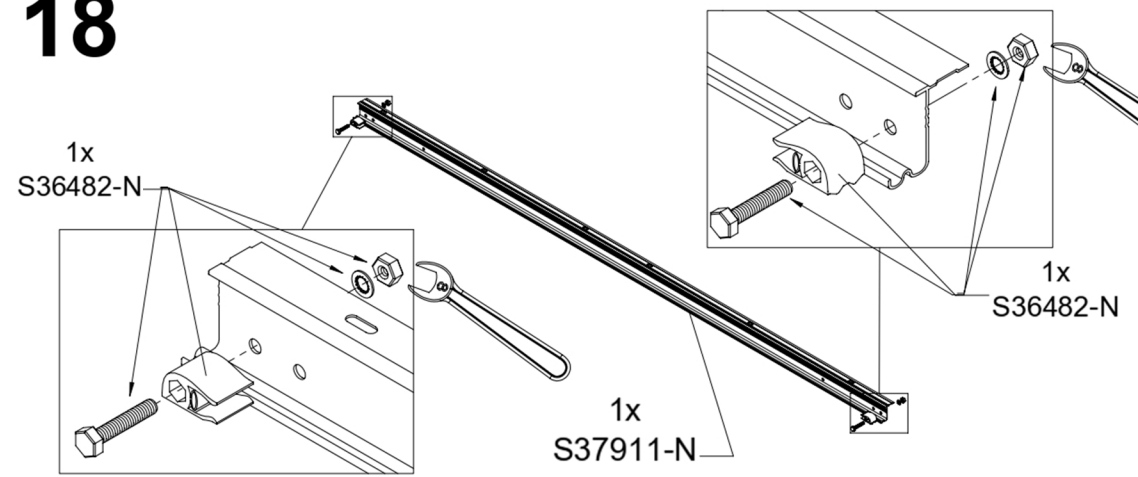

# 19

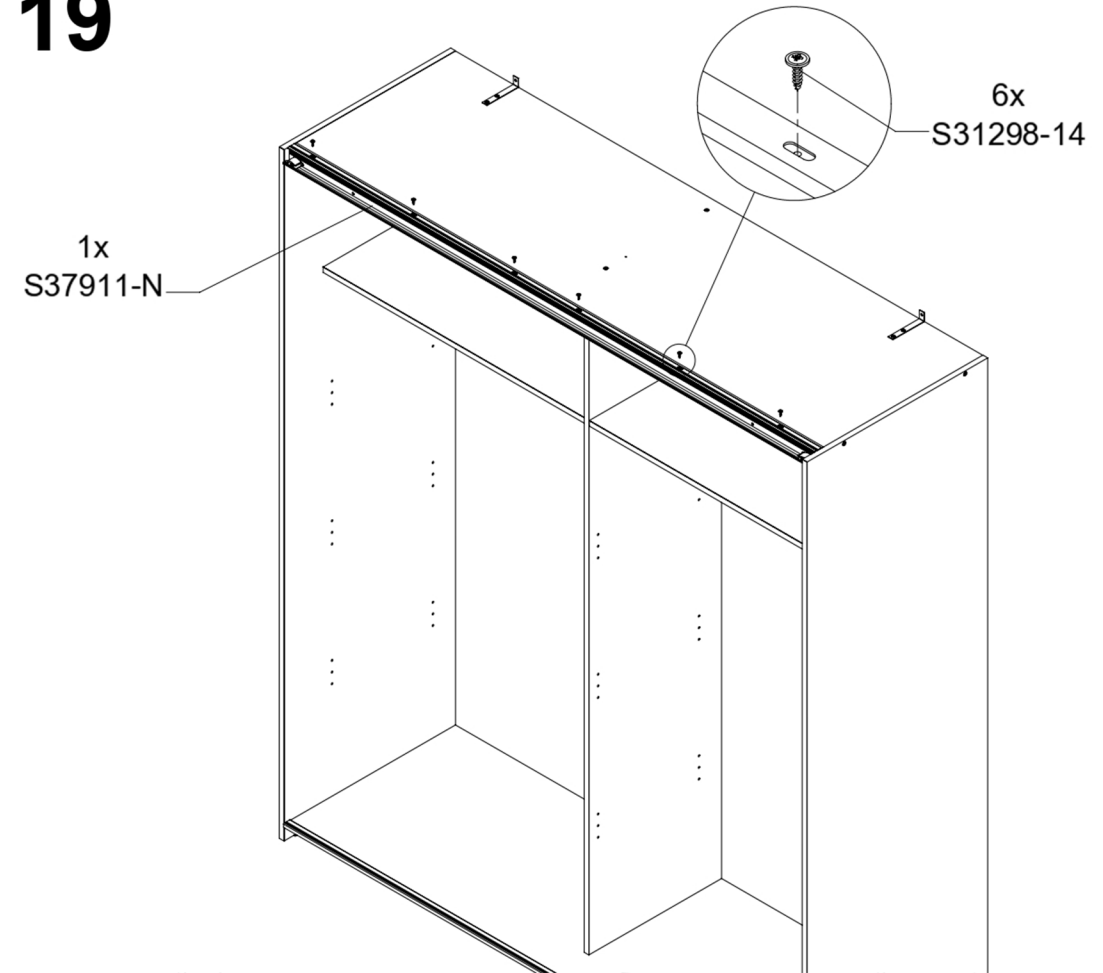



# 20

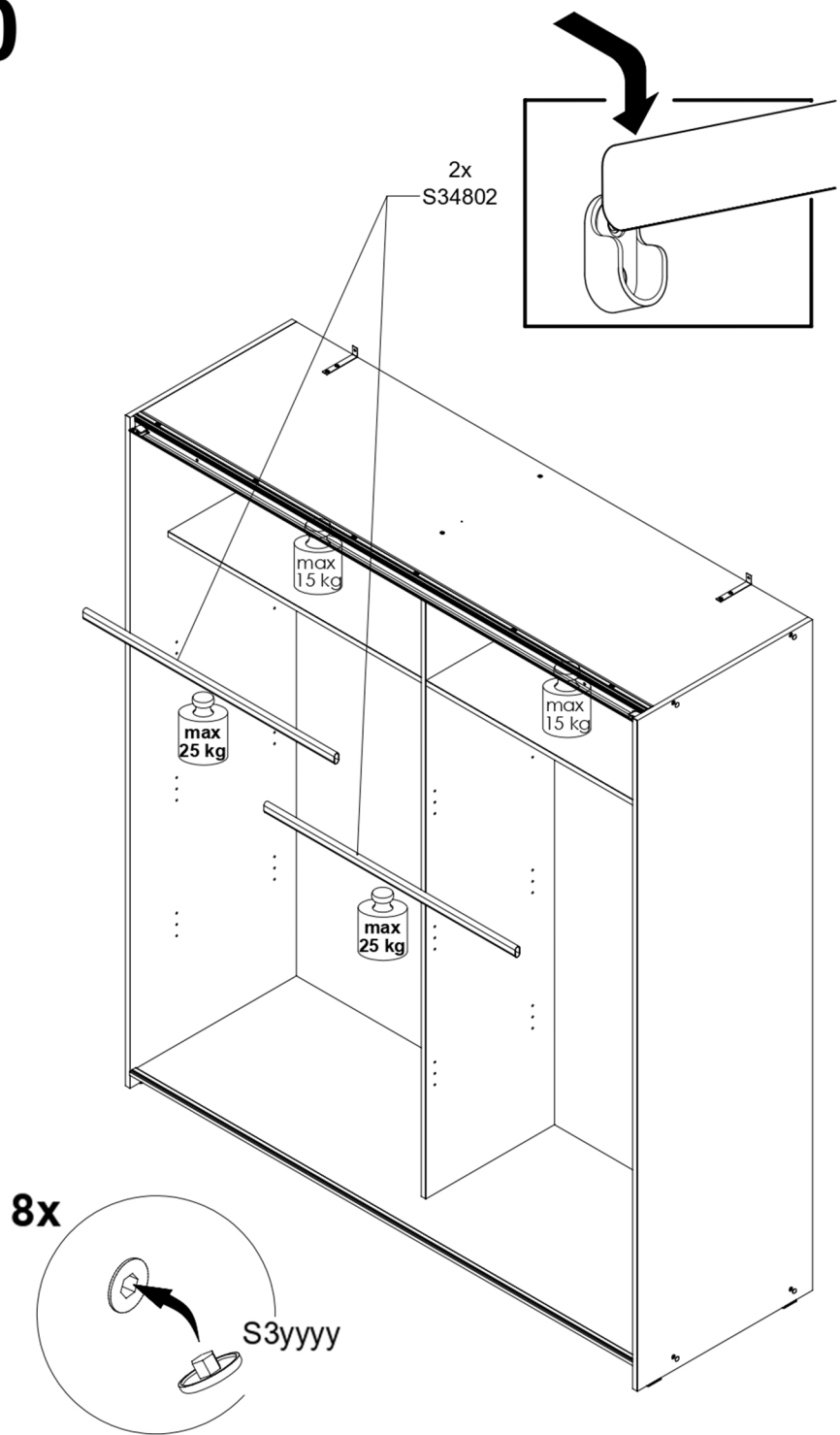

# 21 x1

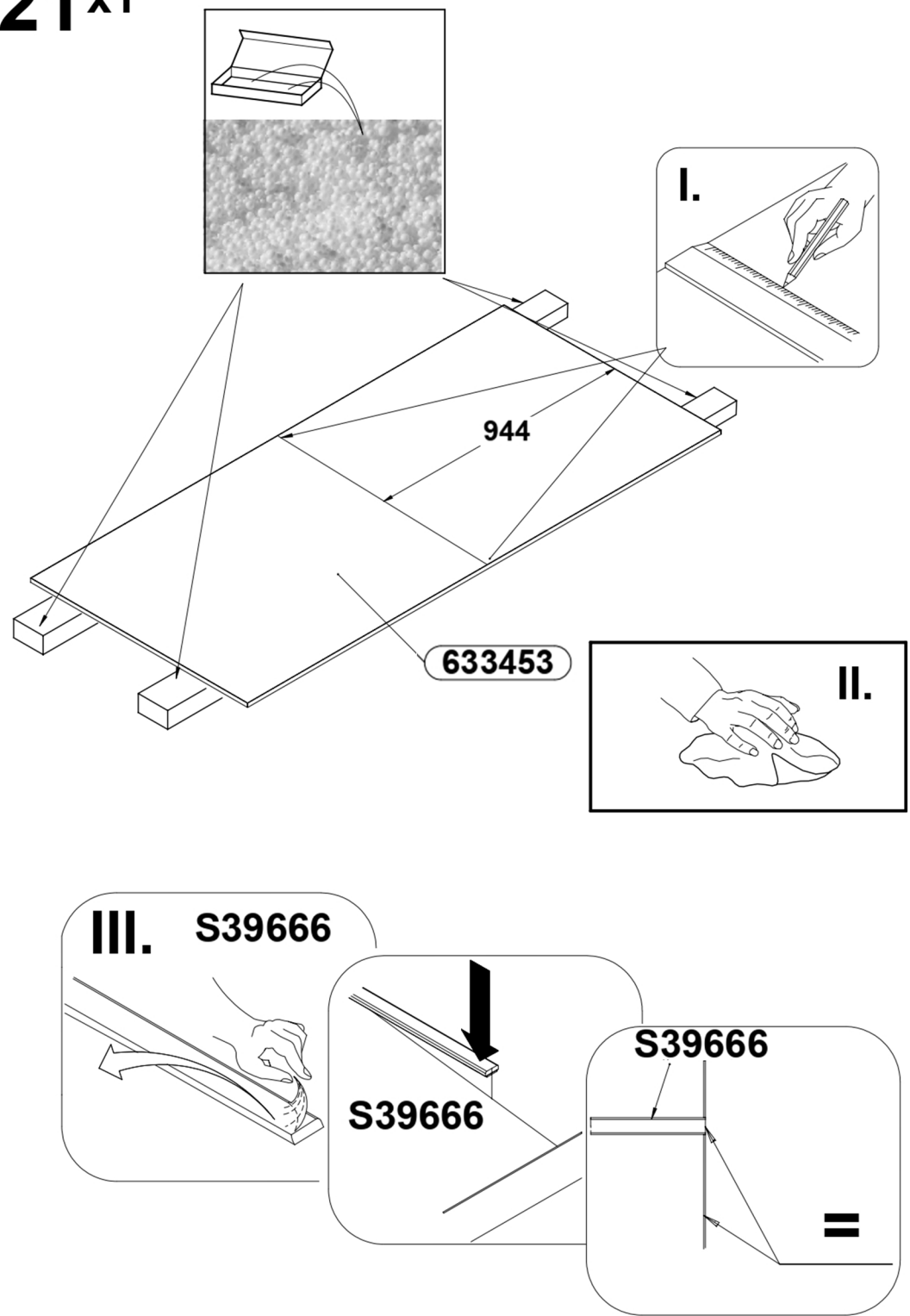

**22** x1

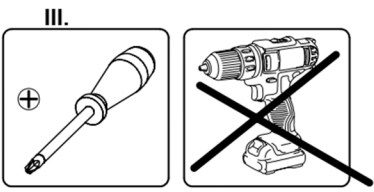
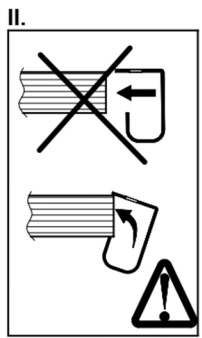
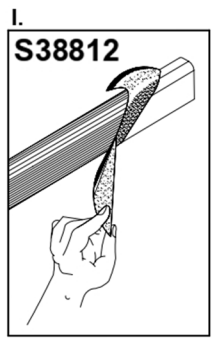

**23** x1

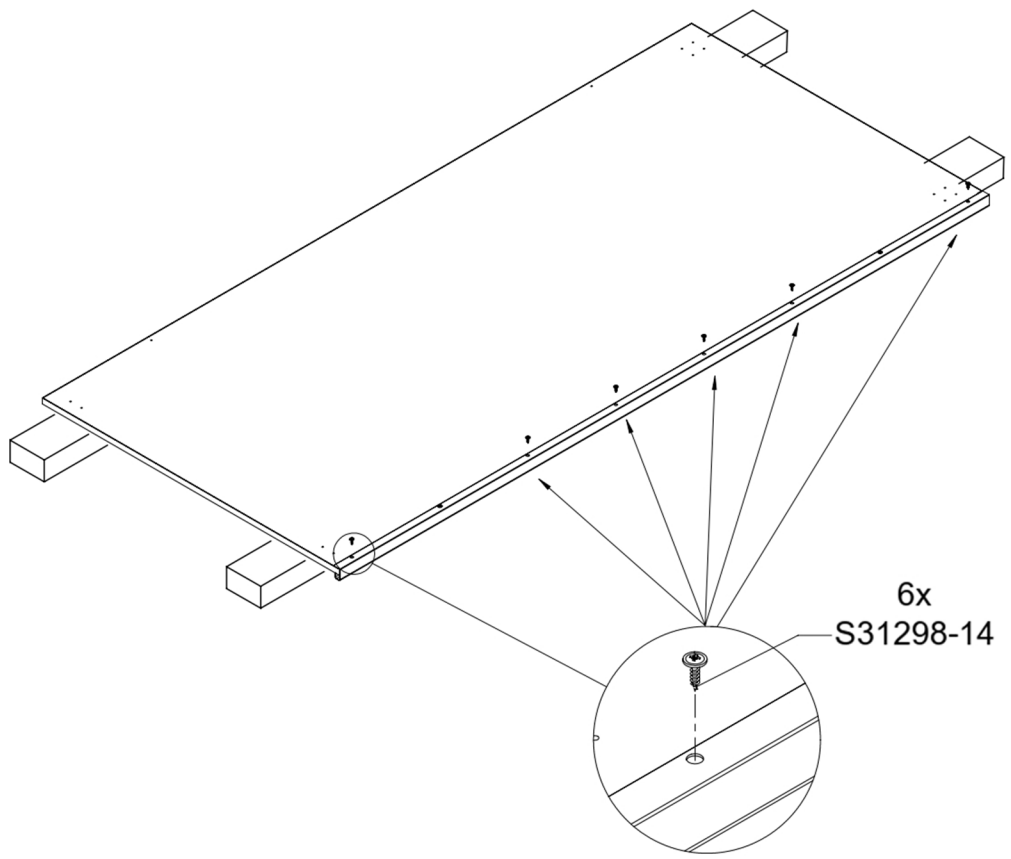
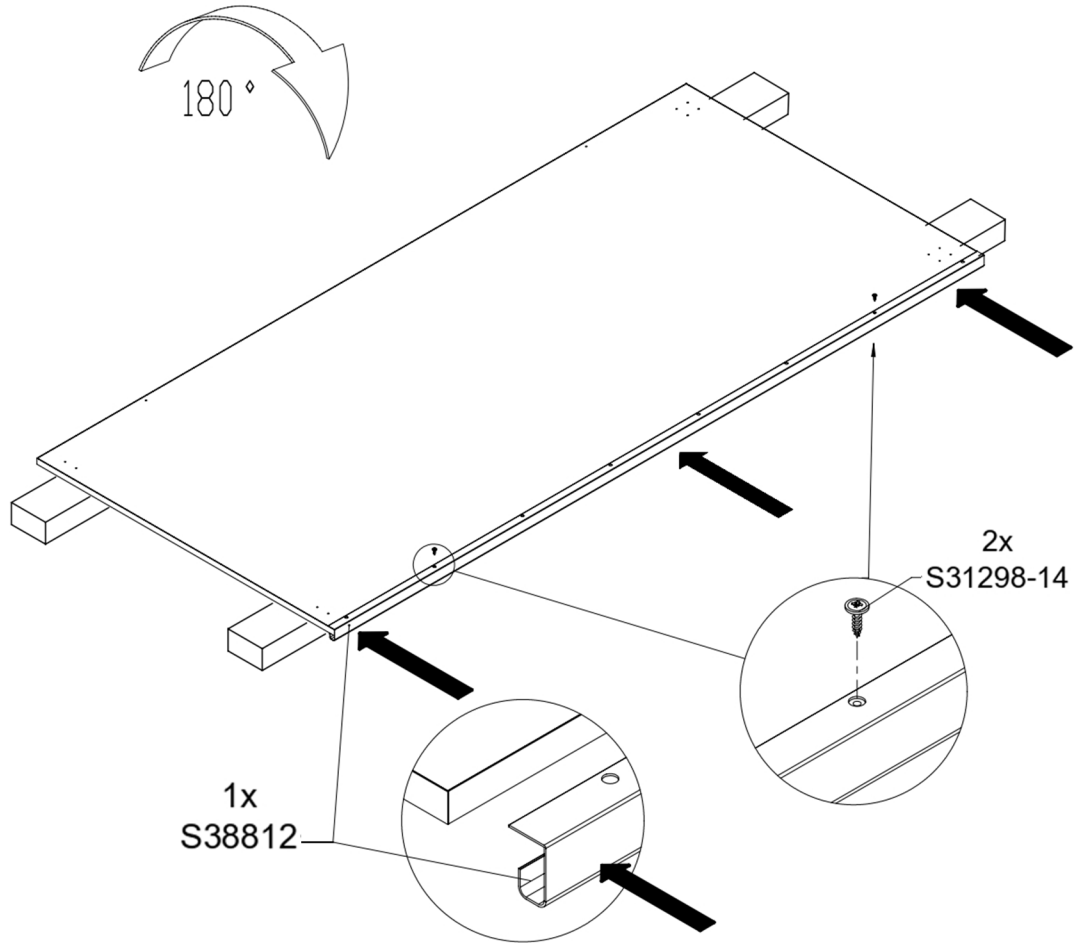
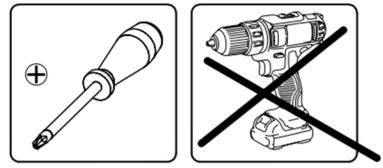

**24x1**

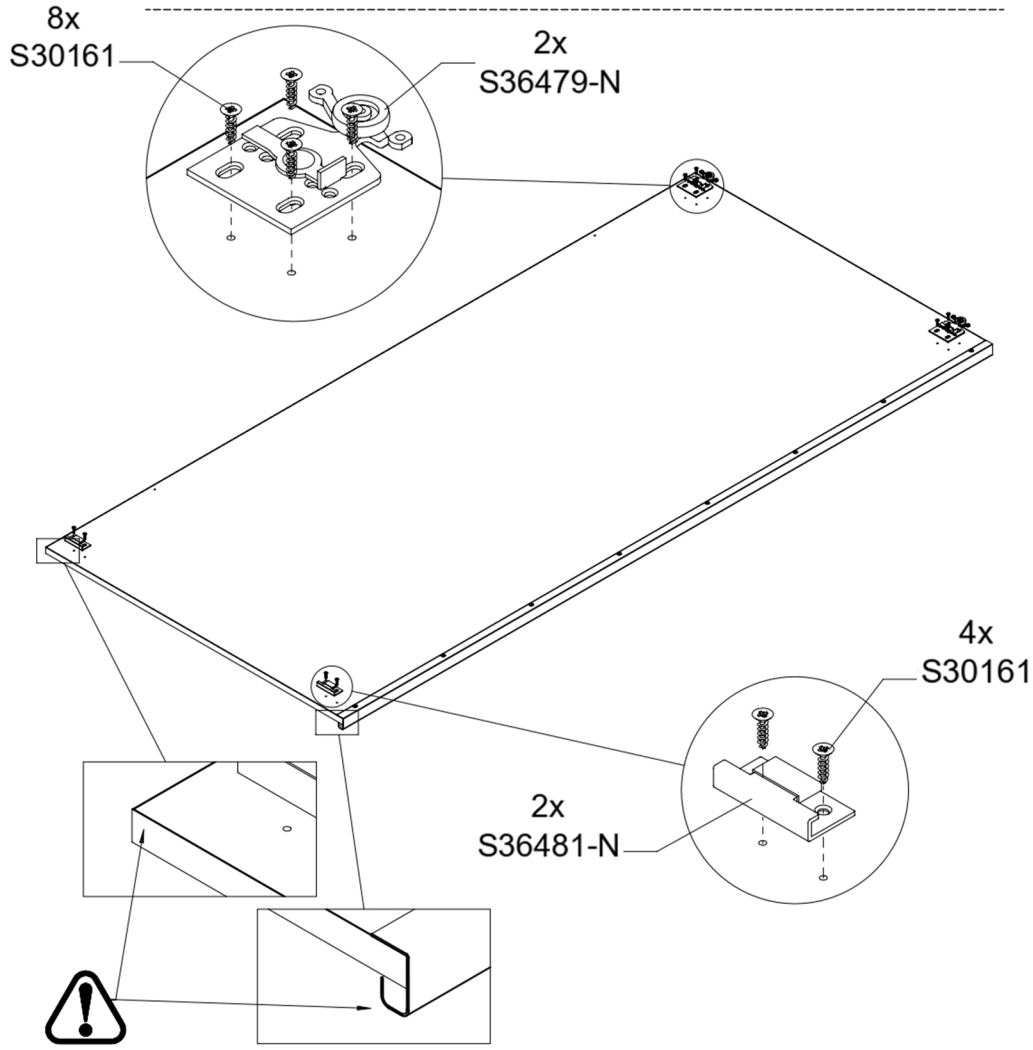
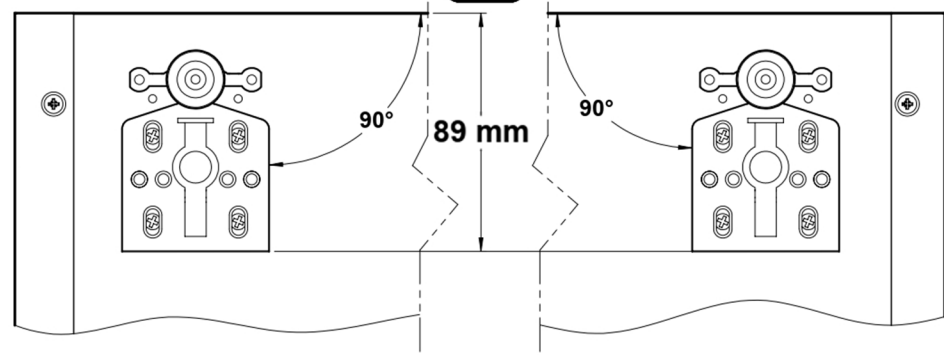

**25x1**

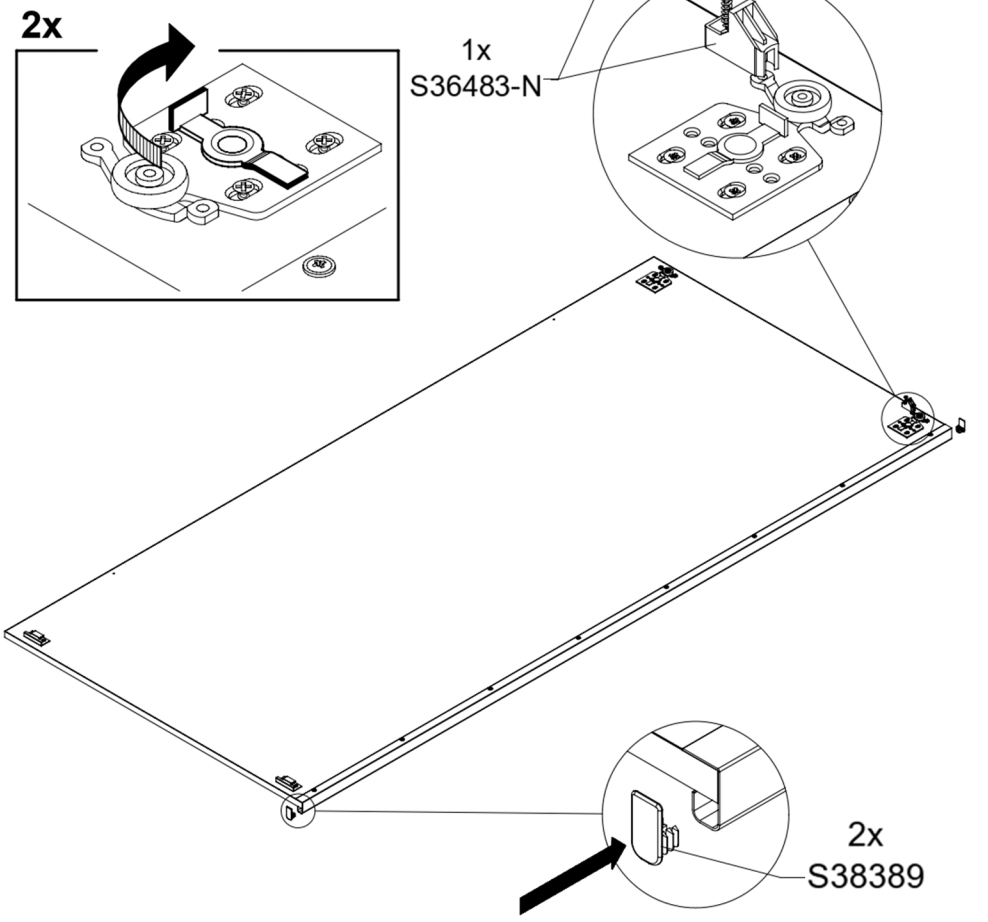
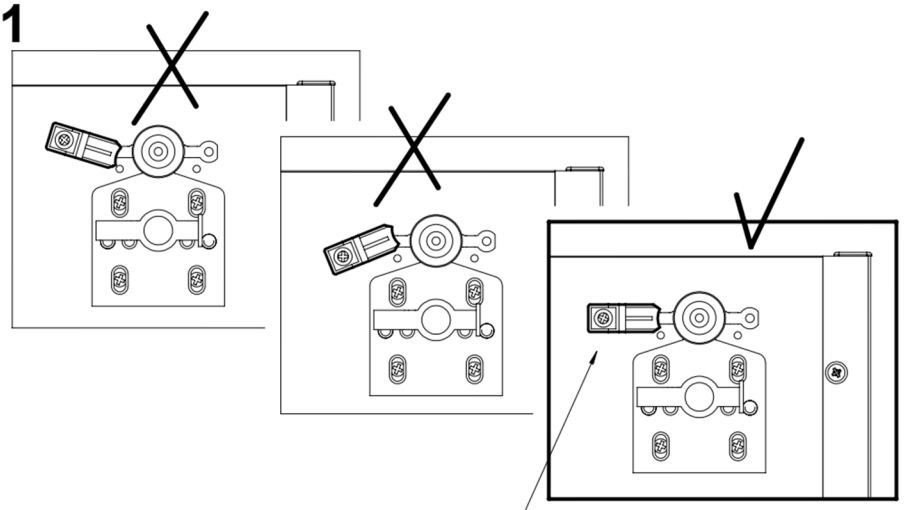

26 x1

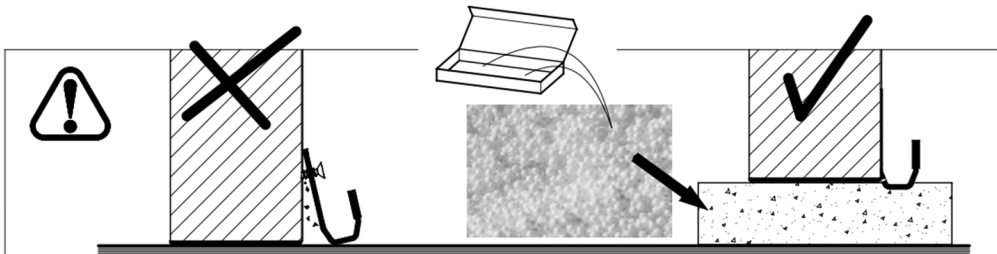
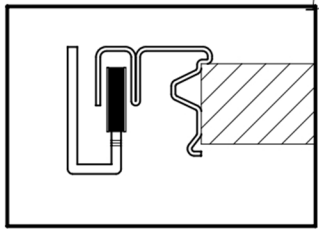
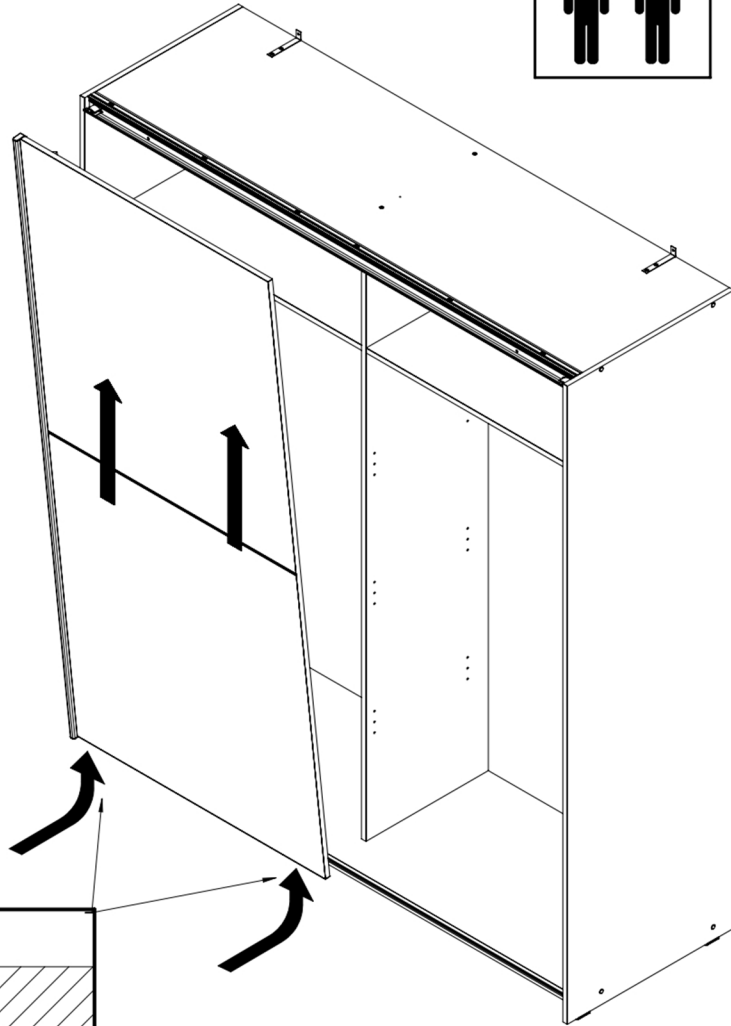
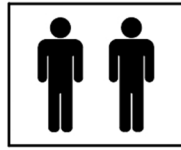

27 x1

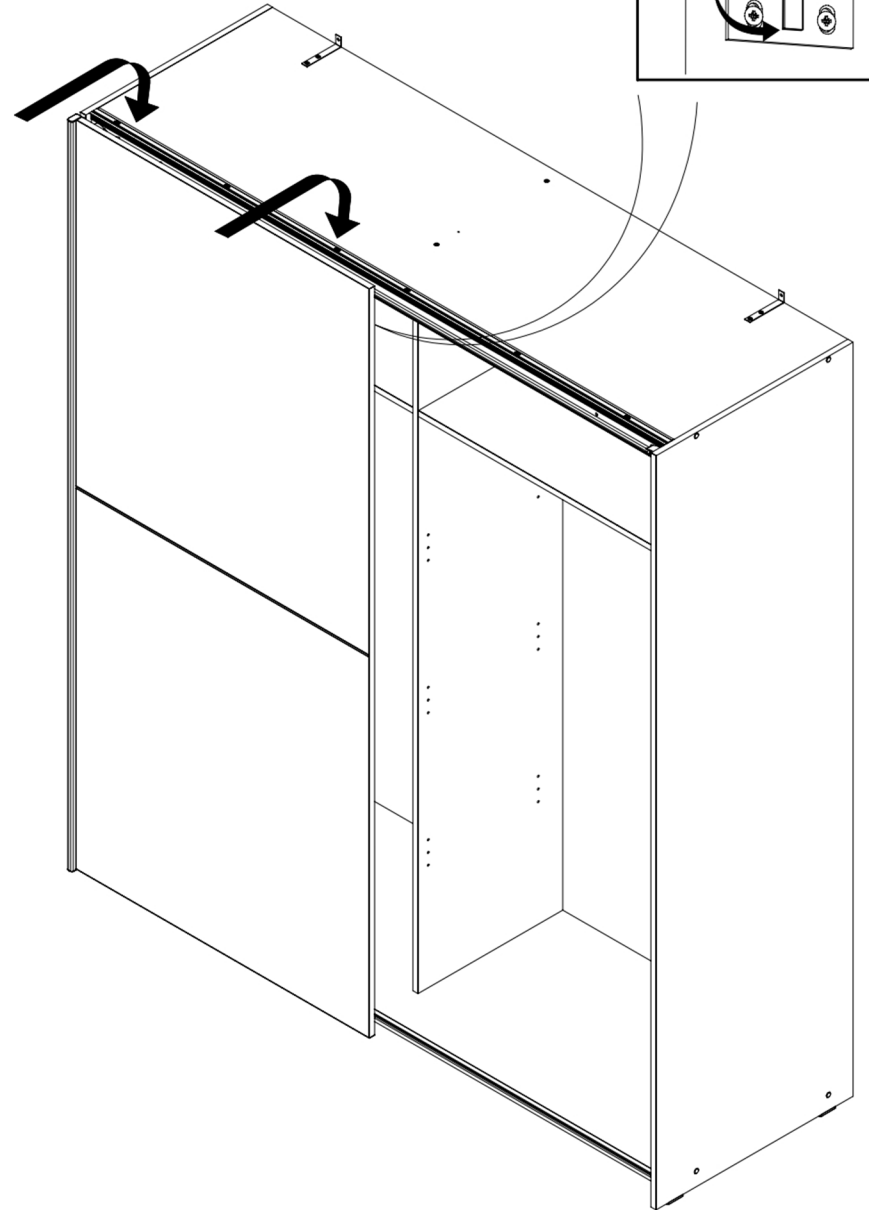
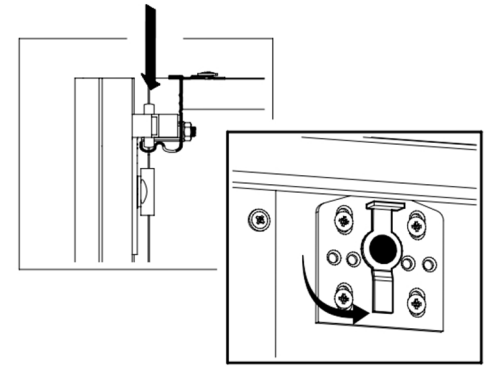



# 28x1

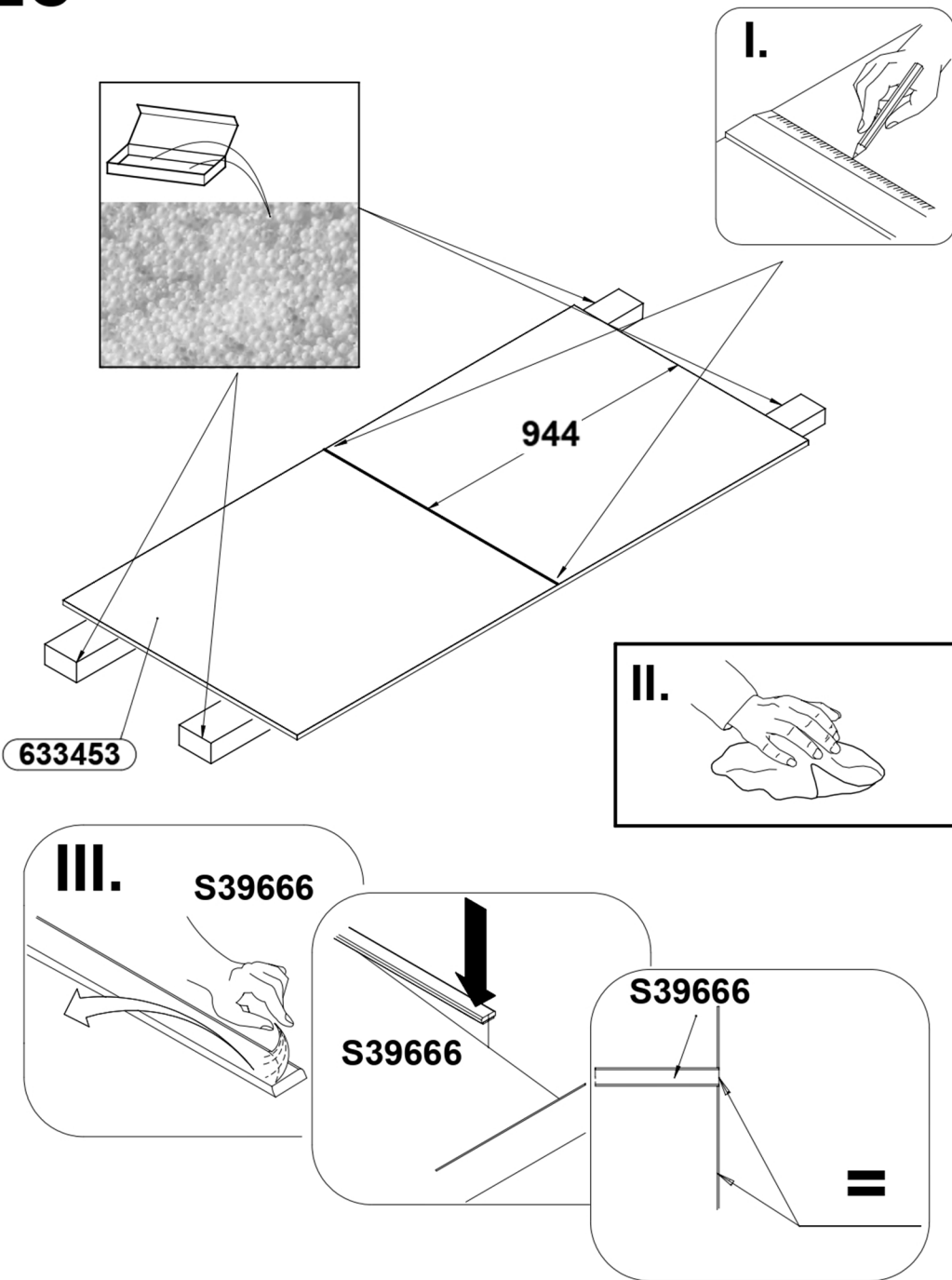

# 29x1

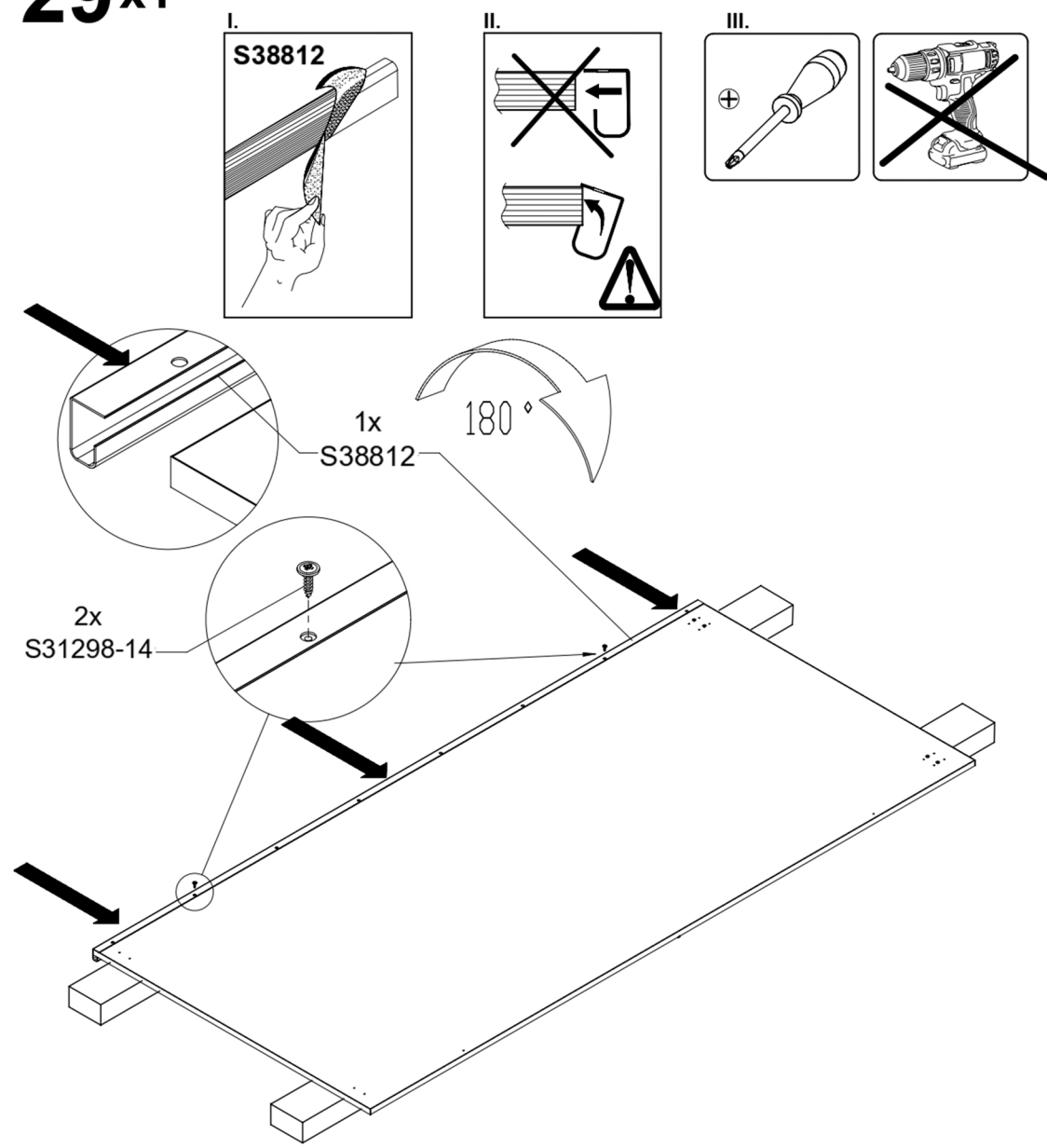

**30**x1

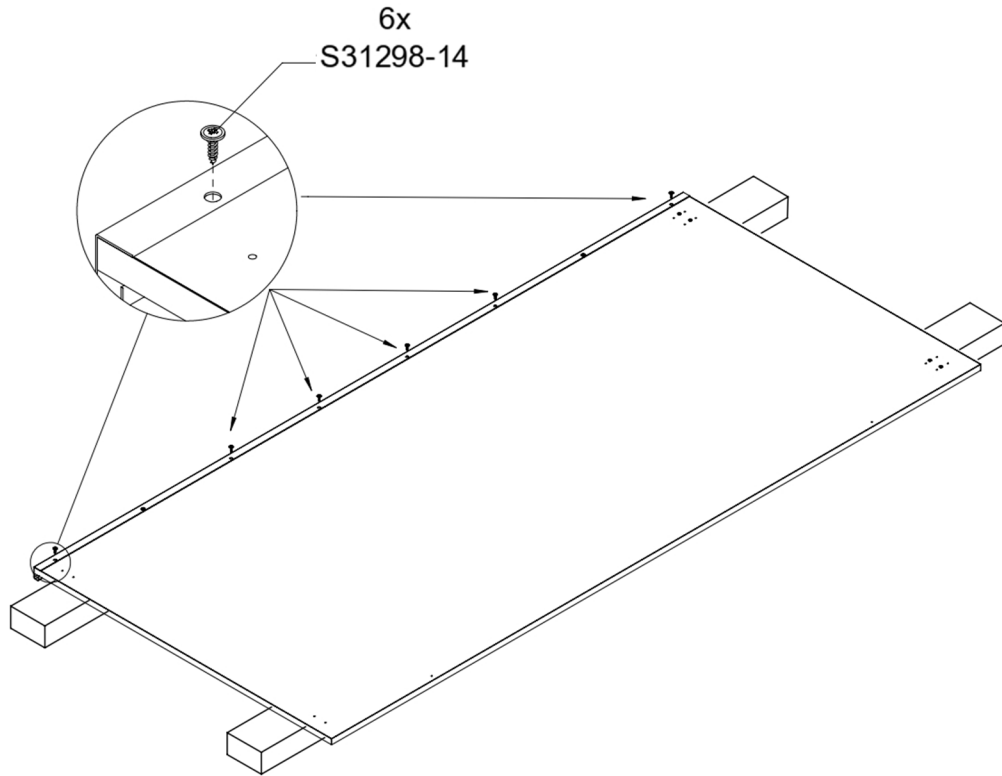
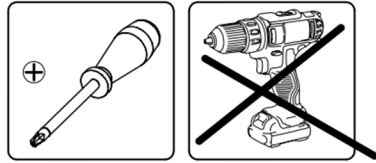

**31**x1

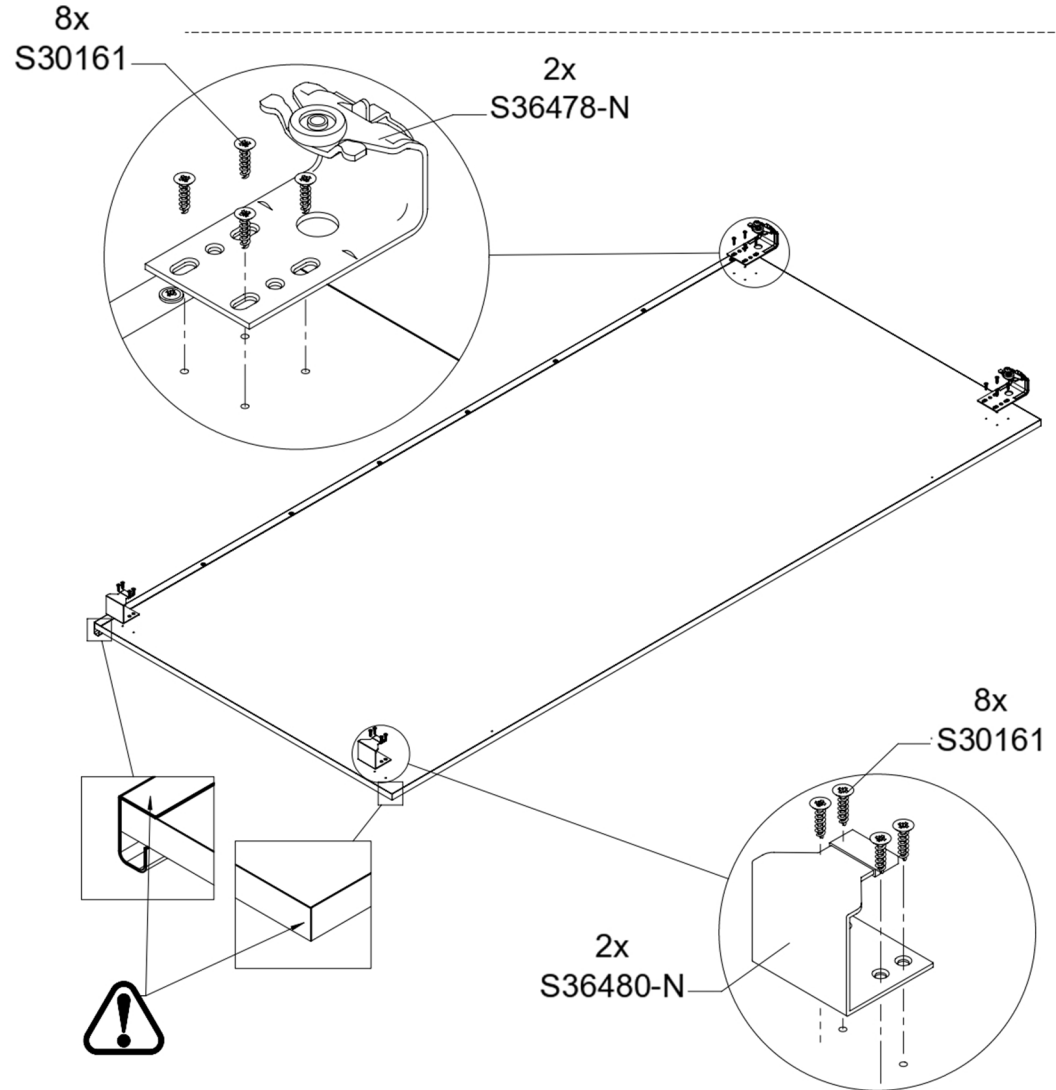
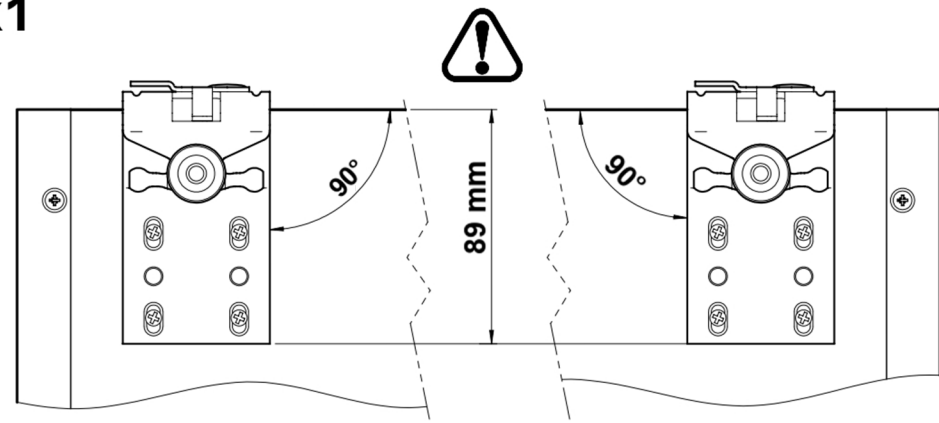

**32**x1

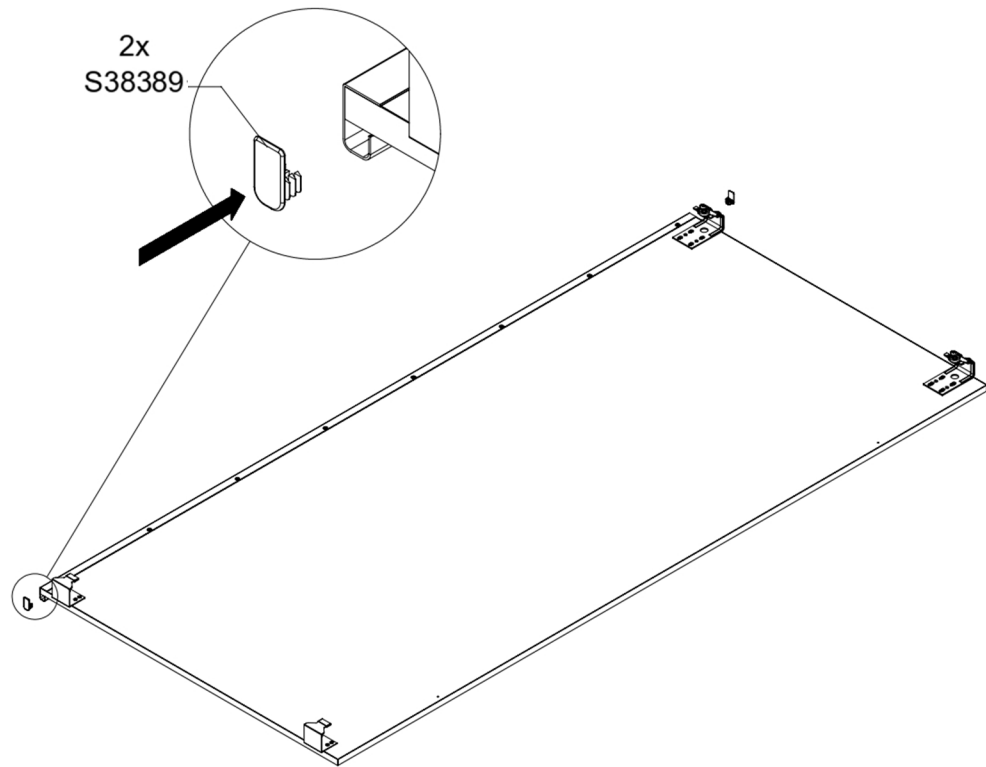

**2x**

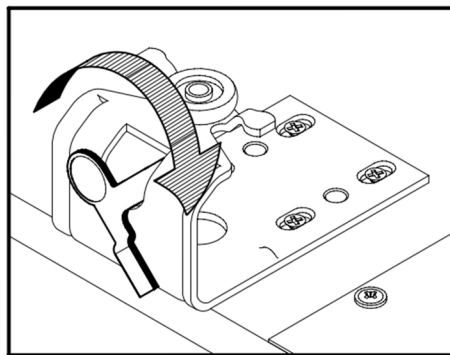

**33**

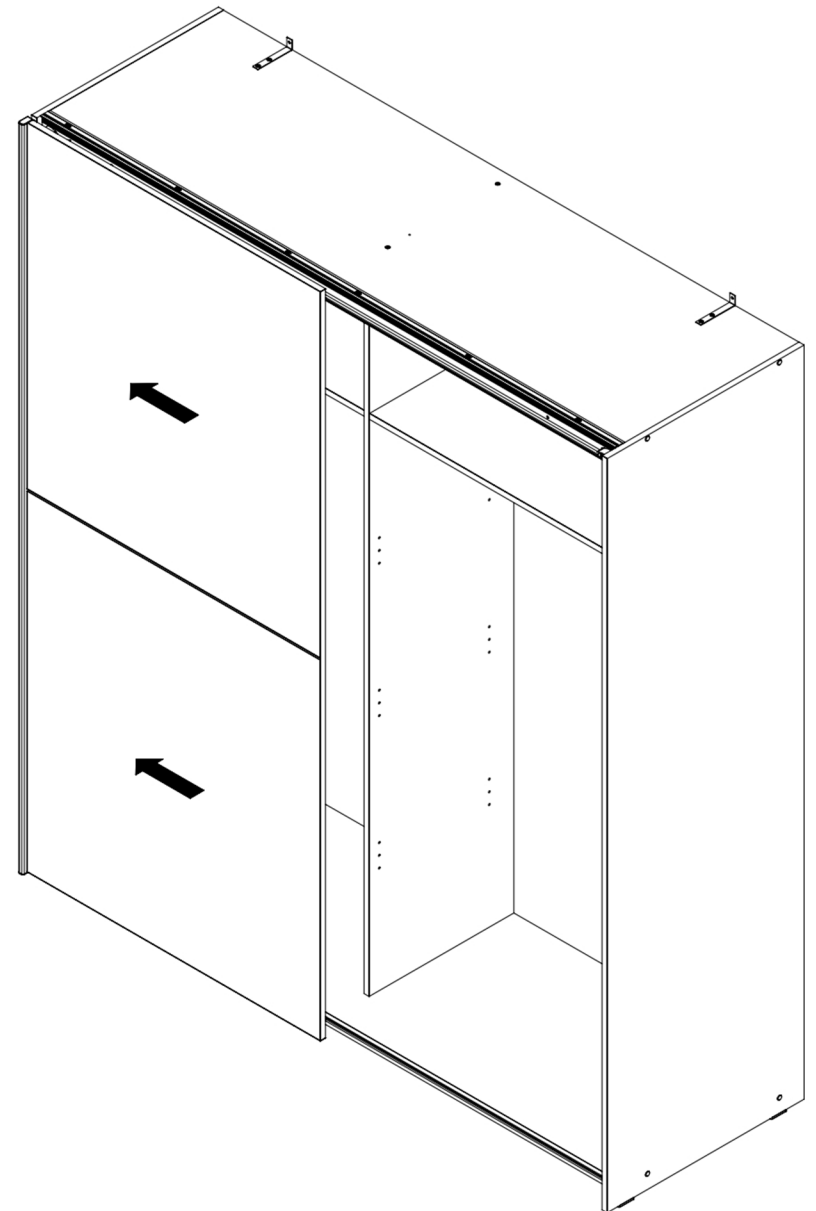

# 34

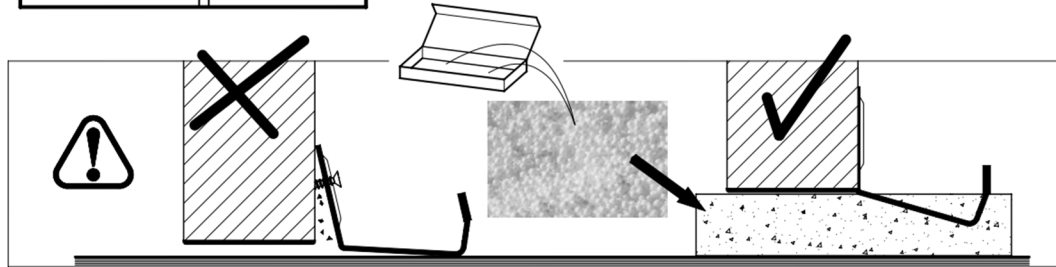
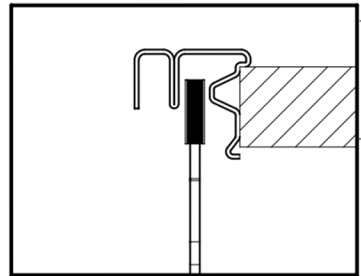
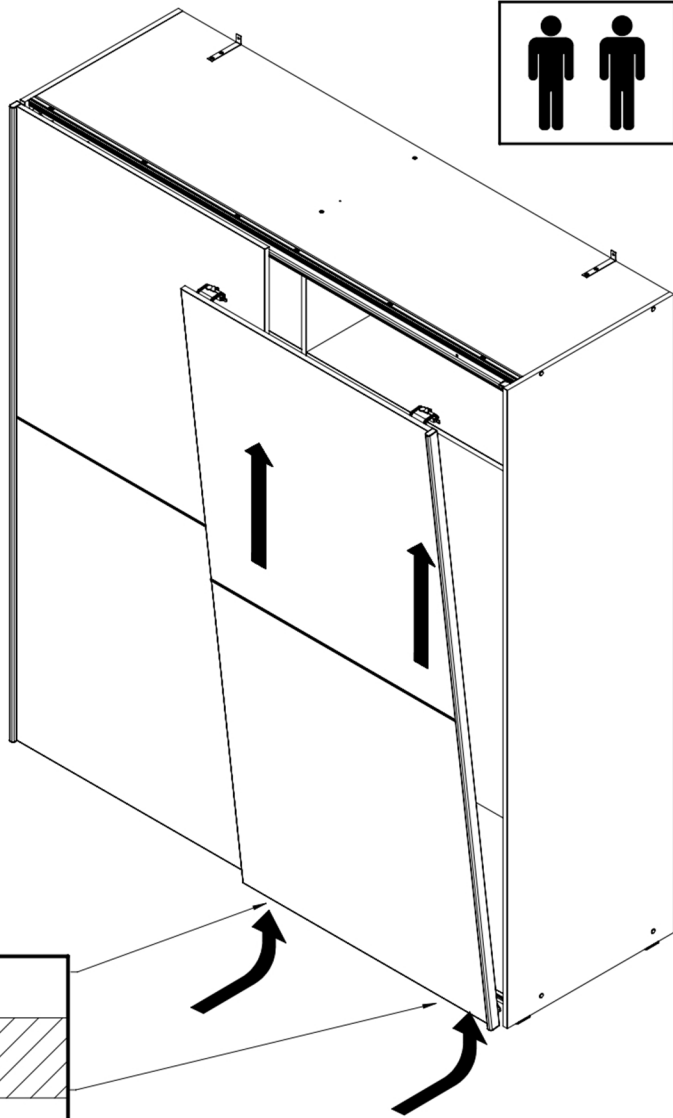

# 36

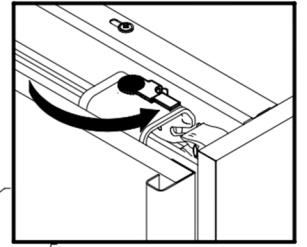
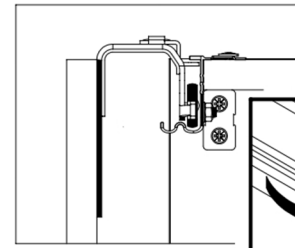
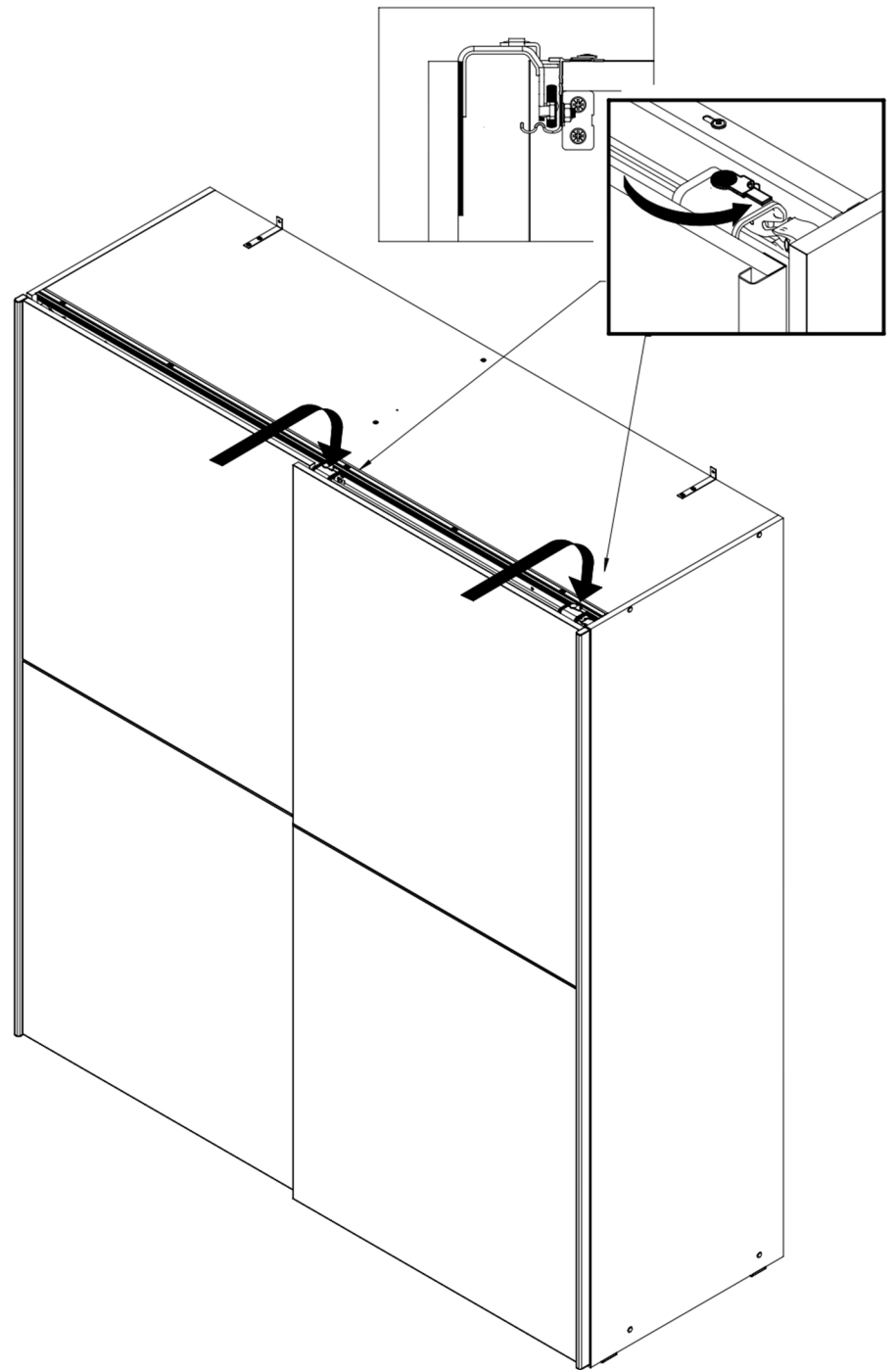



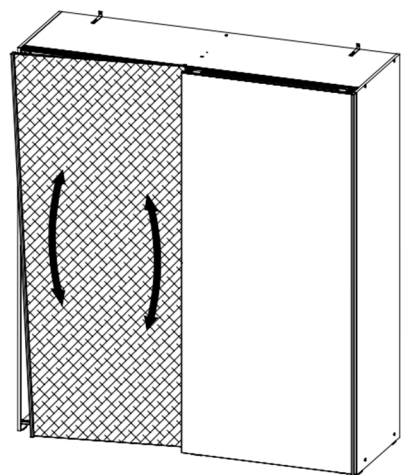

2x

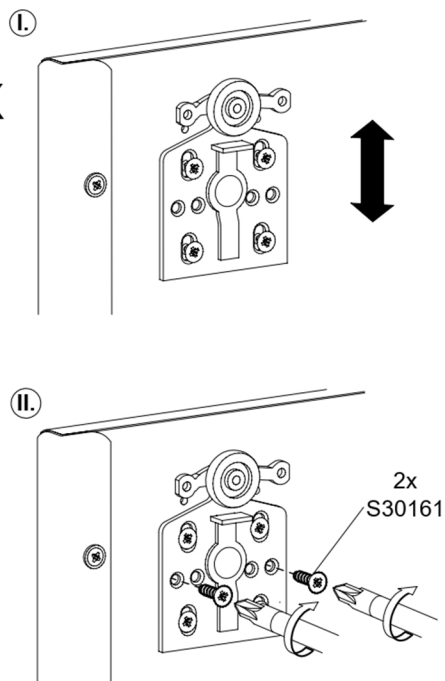

### POKYNY OHĽADOM STAROSTLIVOSTI O NÁBYTOK

Prosíme o dodržovanie nižšie uvedených poznámok pre správnu starostlivosť o nábytok: na čistenie používajte čistú, suchú a mäkkú handričku. Pokiaľ nábytok vyžaduje dôkladnejšie čistenie, možno ho ľahko navlhčiť vodou alebo čistiacim prípravkom určeným na čistenie nábytku a následne vytrieť čistené diely do sucha. Kovové a sklenené časti čistite na trhu dostupnými prípravkami určenými na čistenie tohto typu materiálov zhodne s na nich umiestneným návodom. Nepoužívajte žieravé, brúsne a iné prípravky s neurčitým určením. Čistiace prípravky musia mať jasné označenie, že sú určené na čistenie nábytku.

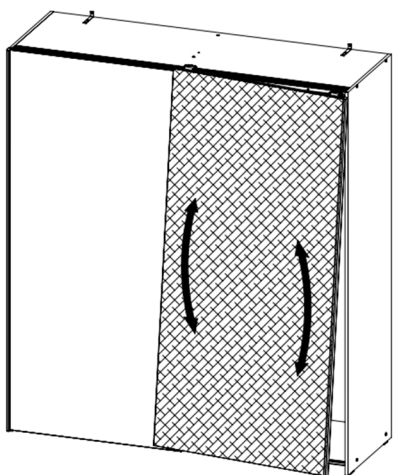

2x

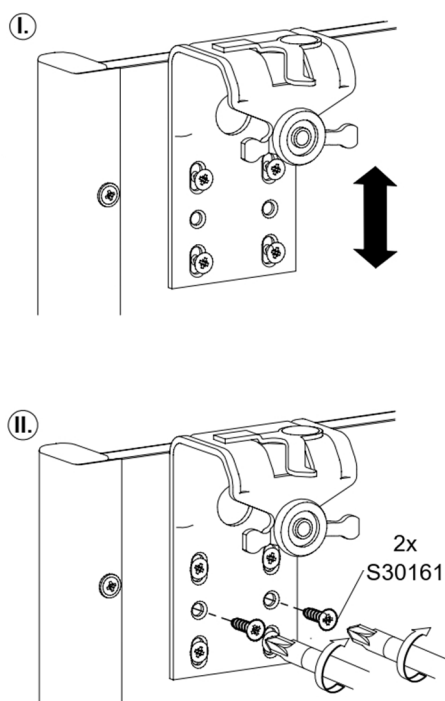

**POZOR!!!** Prvky vo vysokom lesku, z ktorých bola odstránená ochranná fólia, možno čistiť a používať až po uplynutí 72 hodín.